

Turbopumps

The optimal solution for your high vacuum application

Turbopumps

Design and operating principle of turbopumps

Origin

The idea of turbomolecular pumps goes back to the Pfeiffer Vacuum engineer Dr. Willi Becker, who invented the first turbomolecular pump in 1958. This is the ancestor of today's turbopumps.

Technology

Turbopumps belong to the category of kinetic vacuum pumps, which means that gases are moved from the inlet to the exhaust by momentum transfer. The design is that of a turbine: a multi-stage rotor with rotating bladed disks. Stators with similar geometries are mirrored between the spinning rotor disks.

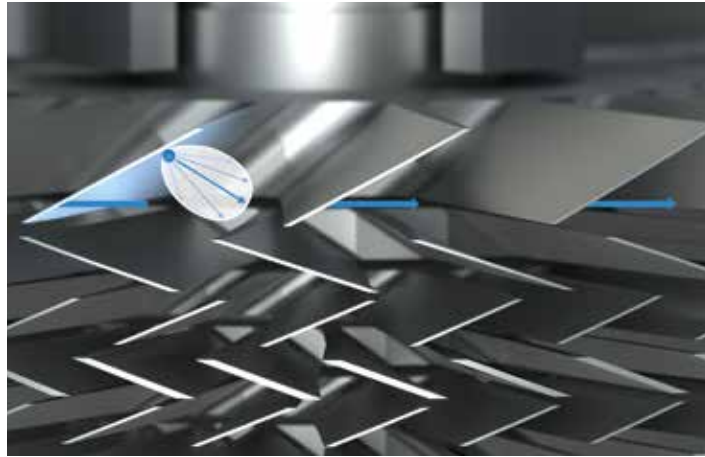

Rotor: Superposition with blade velocity

Molecules that collide with the rotor blades are adsorbed there and leave the blades again after a certain period of time. In this process, blade speed is added to the thermal molecular speed. The stators are needed to re-establish the direction of movement for the next rotor blades. This results in a net pumping effect.

Pumping speed and compression ratio

The two main characteristics that define a turbopump are its pumping speed and compression ratio. The pumping speed describes the ability of the pump to evacuate the volumetric flow, whether it is just the chamber volume or a constant gas flow. The compression ratio is the ability of the pump to work in conjunction with the roughing pump to keep molecules out of the vacuum chamber. Both of these characteristics depend on the gas type.

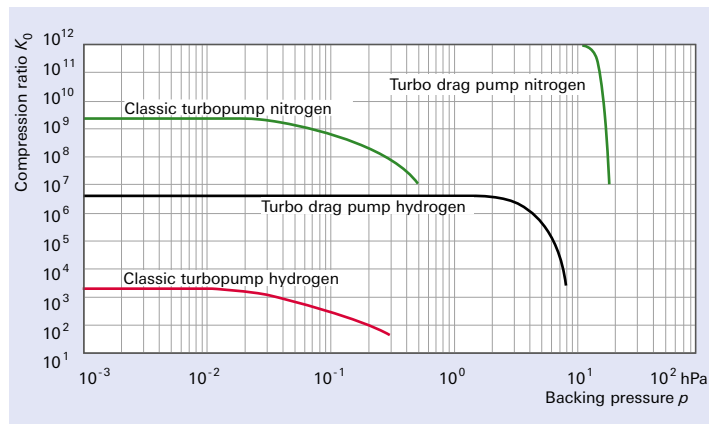

Compression ratios of pure turbopumps and turbo drag pumps

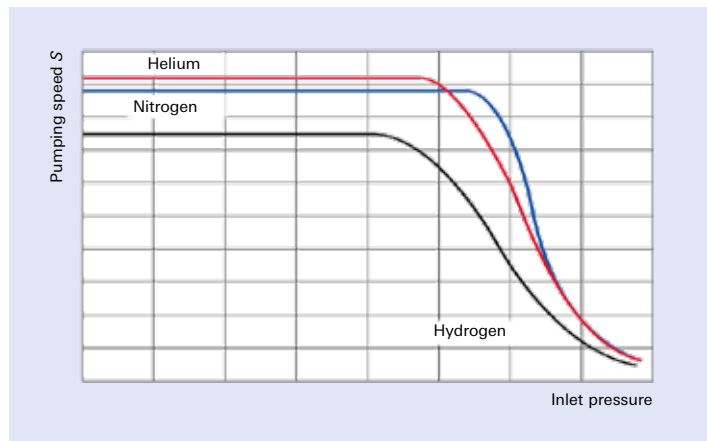

Pumping speed as a function of inlet pressure

Turbopumps

Bearing technologies

Suspension

Pfeiffer Vacuum is using two most reliable design features. The hybrid bearing suspension consisting of a permanent magnet bearing at the high vacuum side of the turbine and a ceramic ball bearing at the exhaust of the pumps. The second concept uses a 5-axis actively controlled magnetic bearing design.

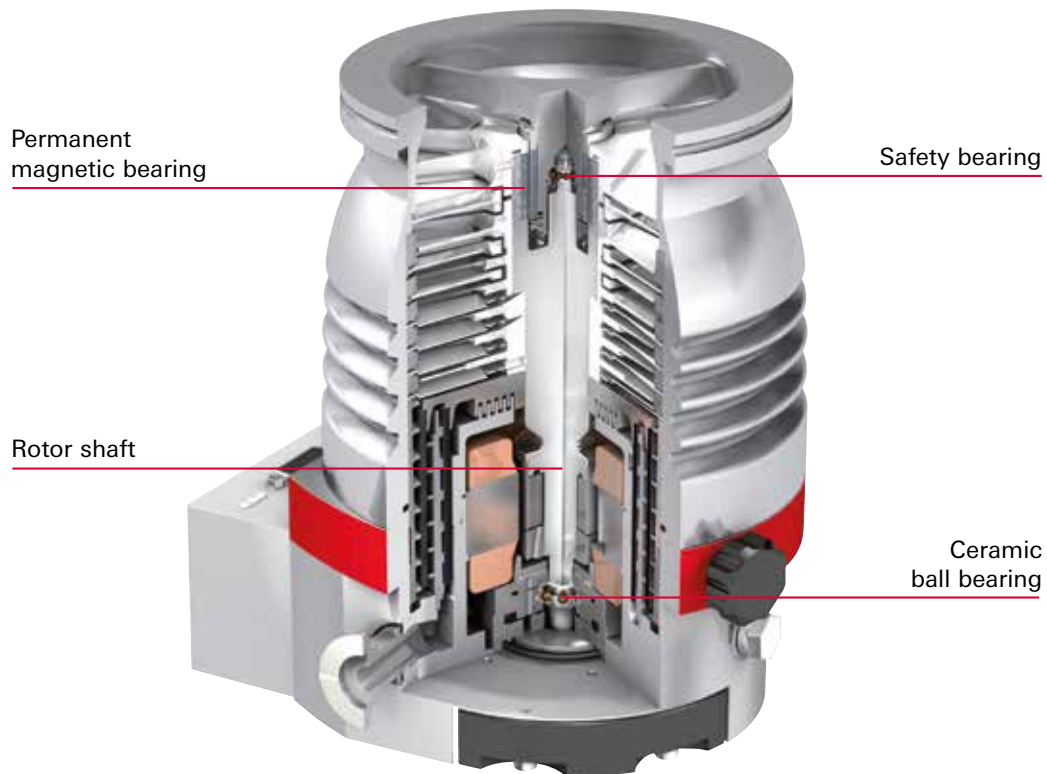

Hybrid bearing suspension

The hybrid bearing suspension was invented by Pfeiffer Vacuum more than 40 years ago. It consists of a permanent magnetic bearing and a ceramic ball bearing. Pfeiffer Vacuum has produced over 1 million pumps with this design resulting in the highest reliability. The magnetic bearing is necessary for hydrocarbon-free radial rotor stabilization in order to achieve extremely ultra-high vacuum ($< 10^{-10}$ hPa). The opposing single ball strongly stabilizes the rotor in both the radial and axial direction, making it resilient to strong shocks such as atmospheric vents and external vibrations. The lubricant reservoir allows for constant filtration that ensures reliability and allows the rotor to easily dissipate heat.

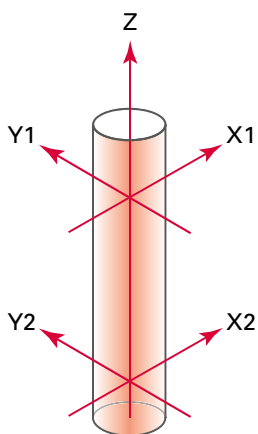
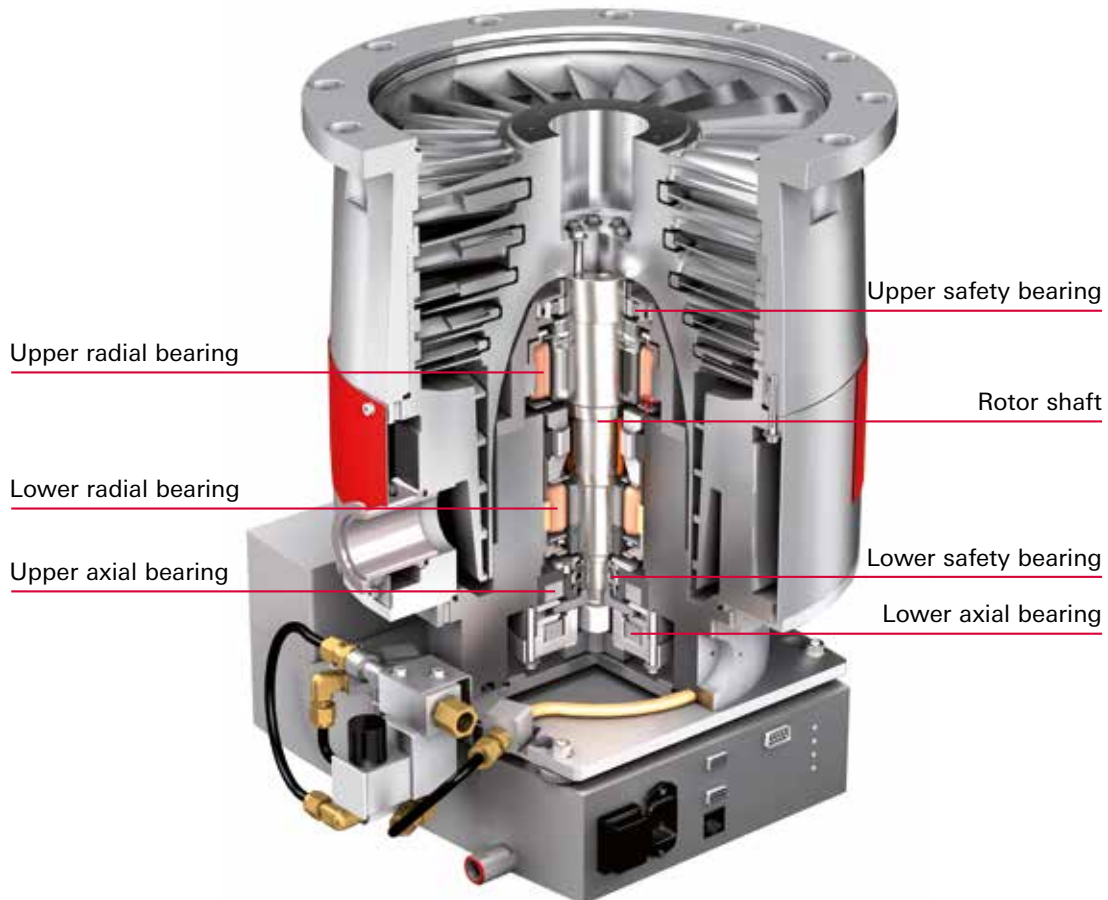

5-axis active magnetically levitated suspension

Turbopumps can also work with a 5-axis active magnetically levitated suspension. The rotor is levitated through digital electronic control and electromagnets. The 5-axis position of the turbo rotor is continuously monitored and readjusted in real time. The magnetic bearing allows the rotor to spin freely in its true axis of inertia, which can differ from the geometric center of the rotor. This counteracts the imbalance of the rotor and enables operation with low vibrations. The complete absence of lubrication eliminates the risk of hydrocarbon contamination in case of system malfunction. In the event of a power failure, the magnetic bearings are supplied with electricity through the rotational energy of the pump until the rotor can land on safety bearings at low speed. There is no need for battery backup or additional safety devices since there is no mechanical contact between the rotor and the housing, the active magnetic suspension system is maintenance free for the complete lifetime of the pump.

Turbopumps

The optimal solution for your high vacuum application

Drive electronics & controllers

Drive electronics are mainly responsible for the safe operation of the high-speed motor drive rotation. In magnetically levitated pumps, the electronics package must also monitor and ensure the proper rotor position and control the active electromagnets. There are different controllers available which can either be mounted directly to the pump or installed as an external rack. Some controllers have internal power supplies so that they can be used with 90–240 VAC while smaller controllers can be driven directly from 24 VDC / 48 VDC. The standard communication is RS-485 or direct I/O (remote). Other communication bus systems such as Devicenet, Profibus, Profinet, EtherCat, E74 or LON are available upon request. Pfeiffer Vacuum offers standard display interfaces for all controllers as well as standard software options.



TC 80 – for small HiPace turbopumps



TC 110, 24 VDC – for small and mid-size HiPace turbopumps



TC 400, 48 VDC – for mid-size HiPace turbopumps



TCP 350 – remote operation for HiPace turbopumps



Magpower – remote operation for ATH turbopumps

Pfeiffer Vacuum turbopump series and specifications:

Pfeiffer Vacuum offers a comprehensive portfolio with all types of turbopumps. Our mature product line has many variations which enables us to provide our customers with the optimal product solution for their vacuum application.

HiPace 10 – 800; HiPace Plus

- Hybrid bearing turbopumps in the pumping speed class of 10 to 800 l/s
- Best size to performance ratio
- High compression for light gases (especially H series)
- Compact yet robust design
- High reliability
- Different product versions providing optimal solutions for different process requirements (H series for high compression, P series for processes and Plus for ultra low vibration)

HiPace 300 M – 800 M

- 5-axis magnetically levitated turbopumps
- Unlimited operational life
- Best vibration performance in the market
- High compression for light gases
- Completely free of hydrocarbons

HiPace 1200 – 2800

- Hybrid bearing turbopumps in the pumping speed class of 1,000 to 2,800 l/s
- High pumping speed for light gas applications
- Good compression
- Robust in harsh applications

ATH 500 M – ATH 3200 M

- 5-axis magnetically levitated turbopumps
- Very high gas throughput
- Optimized for harsh chemistry manufacturing applications as well as light duty high vacuum applications
- Fast safety bearing recovery

Pfeiffer Vacuum turbopump range

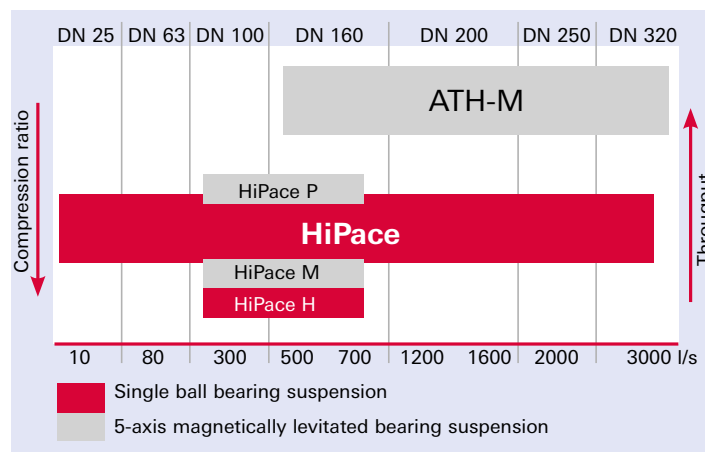

HiPace® 10–800

The optimal solution for your high vacuum application in the pumping speed class from 10 to 800 l/s



Your added value

High gas throughput
and high
pumping speed



Highest reliability
due to robust design
and proven bearing
system

HiPace turbomolecular pumps are reliable, robust and suitable for many vacuum solutions. Their high compression ratio for light gases is ideal for high vacuum applications. A large selection of standard accessories and communications completes the HiPace portfolio.

Pfeiffer Vacuum also offers application specific solutions with pumping speeds from 10 to 800 l/s tailored to better serve specific market requirements such as ultra-high compression, low vibration, and radiation resistance

Benefits of the HiPace 10–800

- High compression ratio for light gases
- Best combination of size and performance
- Robust Pfeiffer Vacuum hybrid rotor suspension
- Radiation resistant pumps with external electronics available
- Standard certifications: UL, CSA, IP54

Patented Laser Balancing Technology

Thanks to the innovative laser balancing technology patented by Pfeiffer Vacuum, the HiPace 80 Neo and HiPace 350/450 have the lowest vibration level on the market as well as minimal noise emission. As a result, they offer the highest precision and are excellently suited for vibration-sensitive applications.

Maximum availability
due to on-site bearing
change



SEMI S2 and
UL certification

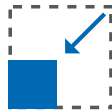
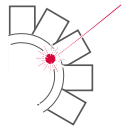

Maximum precision
thanks to patented
Laser Balancing
technology

Minimum space requirement
due to compact design

Flexible use due to arbitrary
mounting orientation¹⁾

¹⁾ HiPace Plus: 0°

Specific product versions for different applications:

HiPace

The standard HiPace turbopump has a compound rotor containing both turbine blades and a holweck drag stage. It provides a good combination of gas throughput and compression ratio. It is ideal for the most common vacuum applications.

HiPace H

The HiPace 300 H and HiPace 700 H turbomolecular pumps are the ultimate high compression vacuum solutions and ideal for generating ultra-high vacuum. The compression ratio for N₂ is $9 \cdot 10^{13}$ and for H₂ is $9 \cdot 10^7$. The HiPace 300 H and HiPace 700 H can easily attain pressures of $< 10^{-10}$ hPa in combination with a simple diaphragm pump.

HiPace P

The HiPace P series pumps are designed for process and light, corrosive applications. The pump rotors are Kepla® coated for corrosion resistance and optimized to operate without a drag stage. If necessary, the pumps can be equipped with a purge device to make sure that no corrosive gases enter the motor section of the pump.

HiPace Plus

The HiPace Plus pumps are optimized for vibration-sensitive applications such as electron microscopy. They have extremely low magnetic stray fields and vibration signatures. Advanced specialized mounting hardware is available.



Please find
further details
and technical
data here

HiPace® 300 – 800 M

Compact turbopumps with magnetic bearings in the pumping speed class from 300 to 800 l/s



Your added value

High gas throughput for all process gases



Reliable due to excellent long-term stability

The turbopumps of the HiPace M series are equipped with a 5-axis magnetically levitated suspension. They are designed for general high vacuum applications and therefore contain compound rotors. The completely oil-free magnetic suspension virtually eliminates the need for maintenance and any possibility for contamination. For vibration sensitive applications, the HiPace M has an extremely low vibration and stray magnetic field. In case of a power outage, the controller attached to the turbopump will use the pump motor as a generator to keep the rotor suspended .

Benefits of the HiPace 300 – 800 M

- 5-axis magnetically levitated suspension
- Completely hydrocarbon-free
- Advanced electronics with power generation motor in case of power outages
- Safety bearing wear counter with robust re-stabilization after impacts
- Integrated drive electronics
- Can operate in any orientation
- UL, CSA, IP54 certification

**Clean vacuum
due to lubricant-free
magnetic bearing**



**Easy
installation**



**Low vibration
and low magnetic
stray field**



**Durable due to
automatic unbalance
compensation**



**Flexible use due to arbitrary
mounting orientation**

Drive electronics TM 700
with interface panel

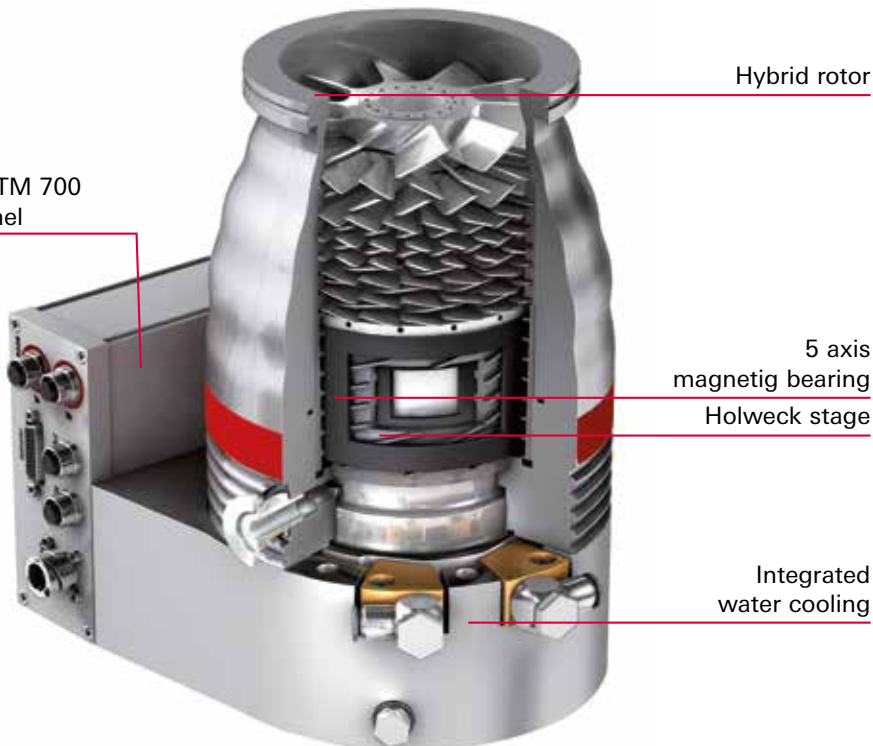

Please find
further details
and technical
data here

HiPace® 1200 – 2800 IT

Compact turbopumps with hybrid bearings in the pumping speed from 1200 up to 2800 l/s



High vacuum performance for light gases (H₂, He) and heavy gases (Ar, CF₄)



Your added value



Maximum reliability through the use of hybrid bearings

The HiPace 1200 – 2800 turbopumps are reliable as well as robust, and therefore suitable for many vacuum applications. Due to the typical use of these pumps in harsh environments, the optimal rotor solution is a pure turbo rotor. Even without a drag stage, these pumps have a sufficient compression ratio for most general applications. A huge complementary portfolio of standard accessories and communication electronics completes this pump range.

We provide application-specific, tailored solutions: e.g. Kepla® coating for corrosion resistance, temperature management systems for the prevention of process deposition in high pressure regions as well as external electronics for use under radiation. The HiPace 1200 – 2800 pumps are a high performing package in a compact design.

Benefits of the HiPace 1200 – 2800

- High compression ratio for light gases
- Robust Pfeiffer Vacuum hybrid rotor suspension
- High resistance to process deposition
- Purge gas valve included
- Available for radiation resistant pumps with external electronics
- Temperature management system
- Standard certifications: UL, CSA, IP54

Maximum availability
due to on-site
bearing change

SEMI S2 compatible,
UL, CSA and TÜV
certification



Highest process
capability, resistant
to particles



Suitable for industrial use
thanks to
protection class IP54

Specific product versions for different applications:

HiPace

With the proven and optimized bearing system and to the good combination between pumping speed and compression ratio, the standard HiPace pumps are suitable for all kind of standard applications.

HiPace C

The HiPace C pumps are designed for corrosive applications. Due to a Kepla® coating of the rotor, for example, they reach an unsurpassed resistance to various process chemicals.

HiPace I

HiPace I pumps are designed especially for Implantation processes. The sophisticated rotor design of the turbopump results in an optimized pumping speed for light gases. This ensures the best process adaption for ion implantation processes, where hydrogen pumping speed is very important. The nickel coated rotor ensures robustness against the dopants applied in the process.

HiPace T

The temperature management system can reduce the amount of process deposition. By increasing the temperature at the higher pressure region, condensation is reduced. This feature can be combined with the C-version (HiPace CT) in order to provide both corrosion resistance to process chemicals as well as resistance to process deposition inside the pump.



Please find
further details
and technical
data here

ATH 500 – 3200 M, ATP 2300 M

Compact turbopumps with magnetic bearings in the pumping speed class from 500 to 3000 l/s



Your added value

Very high gas throughput especially for heavy process gases



Excellent long-term stability and reliability due to magnetic levitated rotor technology

ATH-M and ATP-M 5-axis magnetically levitated turbomolecular pumps have long term reliability in semiconductor fabrication processes and other manufacturing environments such as flat panel display, solar cells or large area glass coating. These applications require high tolerances of harsh chemicals along with high gas flow capabilities. This is where the ATH-M and ATP-M turbopumps are the perfect fit to fulfill today's industry demands. The high performance compound rotors with molecular drag stage of the ATH-M series pumps provide unparalleled throughput and high foreline tolerance even at high temperatures, whereas the ATP-M pumps offering ideal pumping performance for light gases. Both pump series are also widely used in R&D applications due to their maintenance free high quality vacuum generation capacities.

The ATH-M product line offers pumping speeds from the world's smallest 500 l/s class turbomolecular pump up to the 3000 l/s class.

Benefits of the ATH 500 – 3200 M and ATP 2300 M

- 5-axis magnetically levitated suspension
- Completely hydrocarbon free
- Advanced electronics with power generation motor for power outage conditions
- Safety bearing wear counters with robust re-stabilization
- Can operate in any orientation

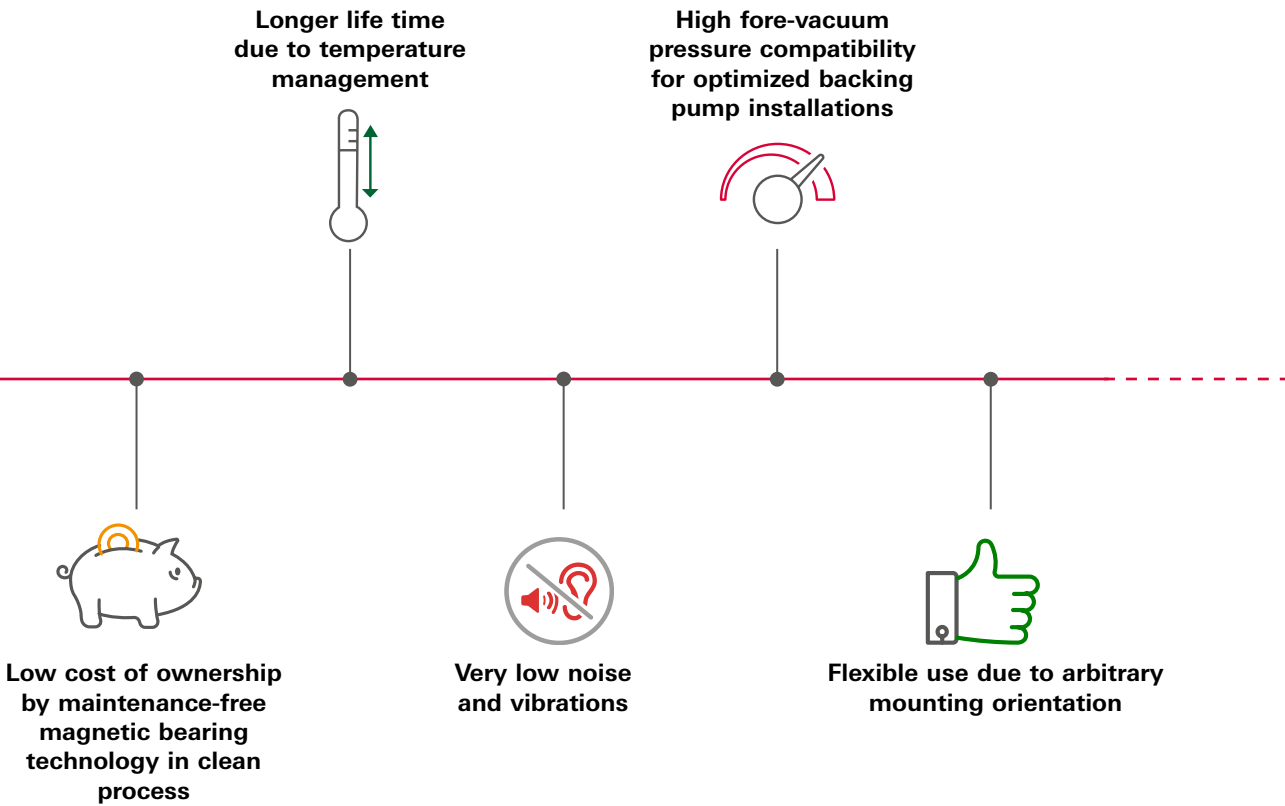

Specific product versions for different applications:

ATH-M and ATP-M non-heated version

The ATH-M has a high compression drag stage that makes it a high flow turbopump for industrial requirements. The ATH-M non-heated versions are designed for light duty applications such as plasma deposition in semiconductor manufacturing processes, large area glass coating or in non-corrosive R&D.

ATH-M and ATP-M heated version

The ATH-M heated version with a temperature management system (TMS) is designed to tolerate harsh chemical process gas from silicon-based manufacturing applications. Its pumping system is equipped with specific protection coatings. The TMS will minimize by-product depositions within the turbopump to maximize the maintenance intervals and allow for a minimum tool downtime.

The ATP-M version with a turbomolecular rotor blade structure (without Holweck stage) provides high compression ratio for light gases. It aims at processes that require an ultra-high vacuum, ultimate pressure or high hydrogen pumping capacity.



Please find further details and technical data here

Turbopumps

Application examples



Portable mass spectrometers

An example for a typical application is mass spectrometry in the field of chemical detection. The products used in these solutions must be compact, powerful, battery-operated and conform to Milspec 810 for ruggedness.

Pfeiffer Vacuum products in use

Turbopump HiPace 10

The HiPace 10 is the smallest commercial turbopump on the market. It is equipped with a dual ball bearing for robust operation on land, sea and air.

- Ultimate pressure $5 \cdot 10^{-5}$ hPa
- 10 l/s N₂ pumping speed
- 24 VDC (max. power consumption 29 W)
- 1.8 kg

Diaphragm pump MVP 010 DC

Dry and oil-free diaphragm pumps with a pumping speed of up to 0.60 m³/h.

- Ultimate pressure < 1 hPa
- 24 VDC
- Direct communication with the turbo controller
- Long service life of diaphragms and valves

Digital piezo/pirani sensor RPT 010

Small digital piezo/pirani sensor for stable gross vacuum measurement independent of gas type.

- Display range 10^{-4} hPa to 1,200 hPa
- Interfaces can be directly connected to turbo controller
- Compact dimensions
- Direct installation, no additional power supply
- No additional gauge cable needed



HiPace 10

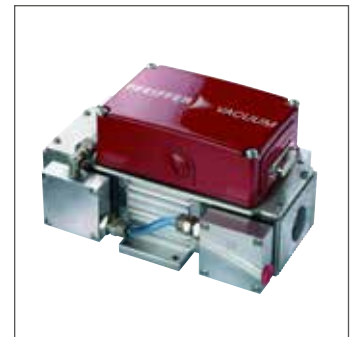

MVP 010 DC



RPT 010

Portable mass spectrometer OmniStar

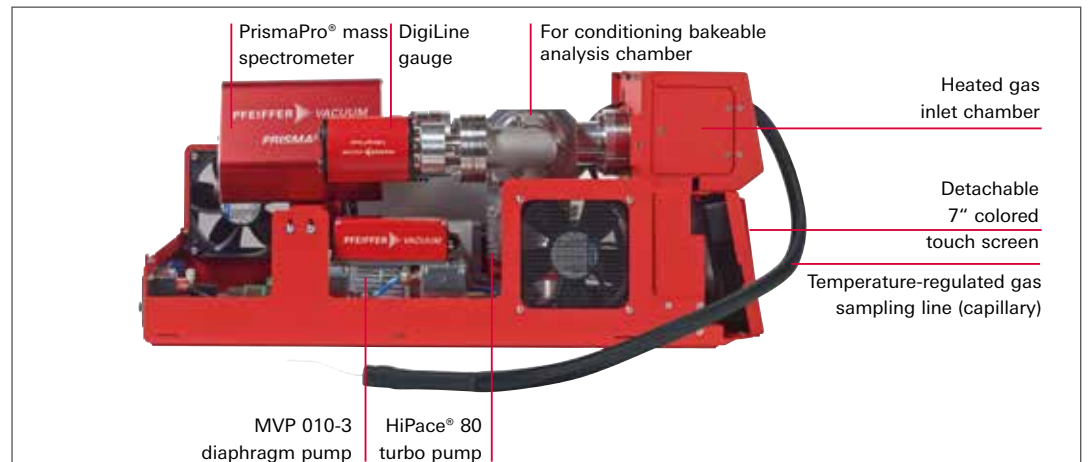



High performance liquid chromatography mass spectrometers

Pfeiffer Vacuum has the solution for high performance vacuum instrumentation applications. We offer standard and customized turbopumps, including SplitFlow turbos.

Pfeiffer Vacuum products in use

Turbopump SplitFlow

With the SplitFlow technology, it is possible to combine multiple turbopumps in a single package. This is especially useful in the atmospheric sample systems of analytic instrumentation such as mass spectrometry

- Short time to market for customized solutions
- Pumping speed up to 700 l/s
- Multiple ports to match your special design requirements
- HV solution for $< 10^{-10}$ hPa
- Unique UHV sealing solutions
- Unique mounting technology



SplitFlow

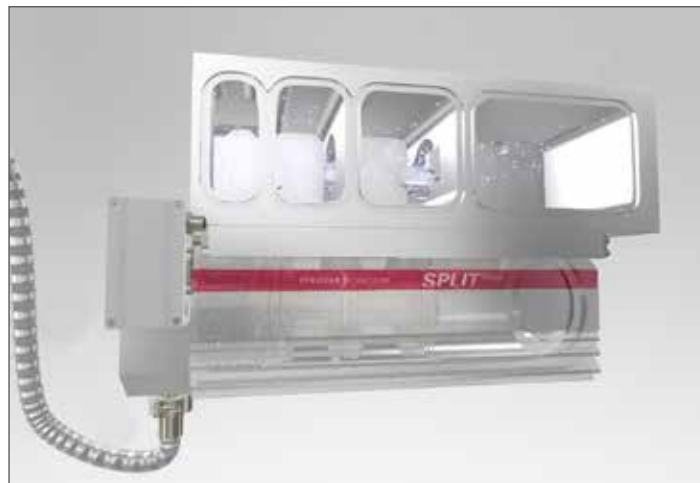

Gasflow in variable chambers

Turbopumps

Application examples

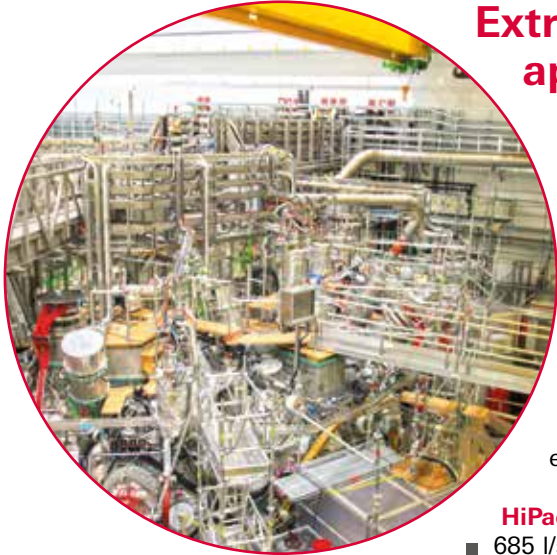

Extreme ultra-high vacuum applications

Pfeiffer Vacuum offers unique solutions specifically designed to reach pressure ranges of $< 10^{-10}$ hPa with minimal effort.

Pfeiffer Vacuum products in use

Turbopumps HiPace 300 H and 700 H

HiPace 300 H and 700 H turbopumps have a high compression ratio, which is especially important for light gases. This allows the pump to achieve high vacuum even with a high foreline pressure.

HiPace 700 H

- 685 l/s N₂ pumping speed
- $< 10^{-10}$ hPa ultimate pressure
- Compression ratio $> 1 \cdot 10^{13}$ N₂ and $2 \cdot 10^7$ for H₂
- Max. foreline pressure 22 hPa

HiPace 300 H

- 260 l/s N₂ pumping speed
- $< 10^{-10}$ hPa ultimate pressure
- Compression ratio $> 1 \cdot 10^{13}$ N₂ and $1 \cdot 10^7$ for H₂
- Max. foreline pressure 30 hPa

ModulLine hot cathode

Pfeiffer Vacuum also offers a true 10^{-12} hPa extractor type hot ion gauge.

- X-ray limit $< 1 \cdot 10^{-12}$ hPa
- Bake-out temperature 400 °C
- Filament Y₂O

Mass spectrometer PrismaPro

Quadrupole mass spectrometers with Faraday detectors are the preferred devices for qualitative analysis of the gas composition in a high-vacuum chamber.

- High measurement speed, stability and high resolution
- Flexible operation thanks to interchangeable analyzers and electronics
- Two filaments mean maximum up-time
- Lowest detectable partial pressure $3 \cdot 10^{-15}$ hPa (hPa)



HiPace 300 H



HiPace 700 H



ModulLine hot cathode



PrismaPro



Radiation emitting applications

Pfeiffer Vacuum offers unique solutions specifically designed to resist radiation. In such applications, the turbopump and gauges must be free of any semiconductor electronics.

Pfeiffer Vacuum products in use

External drive electronics for turbopumps

TCP 350 and TCP 1200 external drive electronics allow turbopumps to be void of any semiconductor electrical components.

TCP 350

The TCP 350 drive electronics unit is employed for driving and monitoring the HiPace 80–800. Available standard cable lengths from 3 up to 120 m and up to 1000 m are available upon request.

TCP 1200

The external electronic drive unit TCP 1200 serves as voltage supply, control and monitoring of a HiPace 1200–2300 turbopump and connected peripherals.

ModulLine gauges heads and controllers

Controller TPG 500

The controllers TPG 500 are modular and can be configured in various ways. Two measuring card slots for the operation of up to 4 gauges are available. An interface slot for various relay and interface cards is included. Fitting for pressure range of $1 \cdot 10^{-11}$ to 1000 hPa.

Gauge head TPR 018

Metal sealed Pirani gauge.

Gauge head IKR 060

Radiation resistant cold cathode gauge head, coaxial, with metal seal.



TCP 350



TPG 500



IKR 060

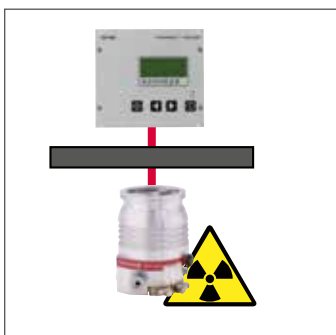

Connection between HiPace and TCP 350



Connection between HiPace and TCP 1200

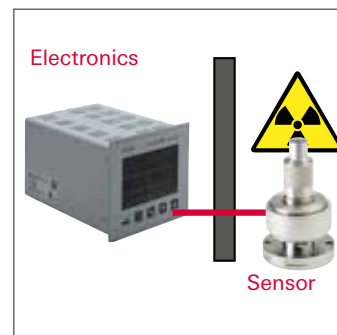

Connection between TPG 500 and IKR 060 sensor

Turbopumps

Application examples

Modular pumping stations



Pfeiffer Vacuum pumping stations can be configured with a variety of turbopumps and backing pumps. Optional gauges are available to be read directly from the turbopump readout or a fully configured gauge controller. Backing pumps are available as either dry or the economical wet version.

Pfeiffer Vacuum products in use

HiCube Eco

Compact pumping stations: ideal for pumping small volumes.

- Turbopumps: HiPace 30, 80, 300 or 300 H
- Backing pump: MVP 015-2, MVP 015-4, MVP 030 (diaphragm pumps)
- Pumping speed $N_2 = 22 - 260$ l/s
- Backing pump = $0.5 - 1.8$ m³/h

HiCube Classic

Robust pumping stations ideal for pumping mid-size volumes (10 – 100 liters), available with wheels.

- Turbopumps: HiPace 80, 300, 300 H, 400, 700, 700 H
- Available backing pumps oil sealed: Duo 3 M, Duo 6 M (rotary vane pumps)
- Available backing pumps dry: MVP 040, MVP 070 (diaphragm pumps)
- Pumping speed $N_2 = 35 - 665$ l/s
- Backing pump = $2.3 - 6$ m³/h

HiCube Pro

Mobile pumping stations ideal for pumping large-size volumes (50 – 1,000 liters).

- Turbopumps: HiPace 80, 300, 300 H, 400, 700, 700 H
- Available backing pumps oil sealed: Duo 11 M, Duo 20 M, Pascal 2010, Pascal 2021 (rotary vane pumps)
- Available backing pumps dry: ACP 15, ACP 28 (dry multi-stage Roots pumps)
- Pumping speed $N_2 = 35 - 665$ l/s
- Backing pump = $9 - 22$ m³/h



HiCube Eco



HiCube Classic



HiCube Pro

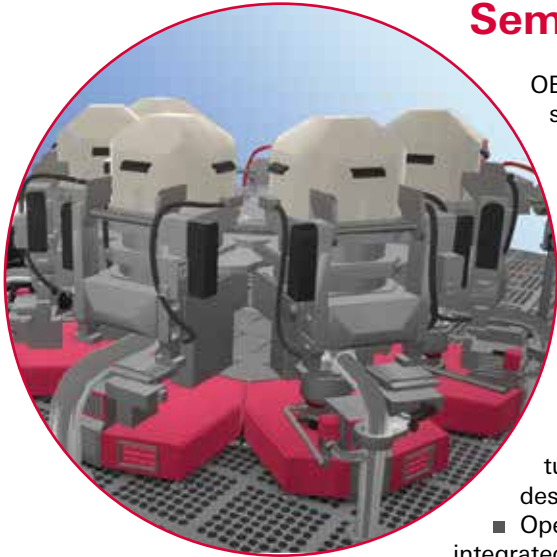

Semiconductor fabrication

OEM equipment upgrades as well as full fab solutions are also part of the Pfeiffer Vacuum portfolio. We have dedicated harsh duty and high throughput turbopumps for the most demanding Etch applications. We also offer ultra-high vacuum, low vibration solutions for our electron beam and lithography customers.

Pfeiffer Vacuum products in use

Turbopump ATH 2804 MT

High temperature and high throughput turbopumps designed for harsh Etch processes.

- Operation with compact pump integrated controller
- Installation in any orientation
- Water cooled
- CE marked and ROHS compliant
- Heated version (MT) available for corrosive applications.

3-position pendulum valve

These valves offer the user a highly reliable, compact and low-cost alternative to competitive designs. In addition, the smooth actuation results in low particle generation and rapid open-to-close speeds. The valve body can be heated to 150 °C with optional heater jackets. In-situ serviceability of the valve is made possible through the incorporation of a removable bonnet cover.

Multi-stage Roots pumps A4X series

Equipped with the proven and energy efficient multi-stage Roots technology, the A4X series offers a wide range of dry pumping solutions designed for the most corrosive applications. The pumping speed varies from 160 to 3,000 m³/h.

- High efficiency motors and limited use of electrical heaters
- Corrosion resistant materials for increased lifetime
- Wide operating temperature range protects the pump against precursor cracking or condensable deposition
- Extended monitoring functionalities for accurate control of pump operating conditions and idle mode capabilities
- Semi S2-0712 and UL 61010 compliant

Leak detector ASM 390

Optimized for fast and accurate leak testing in all measurement ranges. The ASM 390 is the perfect combination of high dry pumping performance, sensitivity and mobility in the smallest footprint.

- Dry and clean pump with high backing capacity (35 m³/h)
- Fast time to test: unrivalled performances from small to large volumes
- High maneuverability flexibility and compact design
- Large color touch screen, fully rotatable and detachable without any tool
- Integrated toolbox for storage of accessories
- Connectable DN 25 exhaust for connection to a general Fab exhaust



ATH 2804 MT



3-position pendulum valve



A4X series



ASM 390

Turbopumps

Application examples

Coating applications



Pfeiffer Vacuum offers complete pumping solutions for a wide variety of thin film vacuum coatings, ranging from decorative to solar panel coatings. These applications require industrial harsh duty pumps with high reliability.

Pfeiffer Vacuum products in use

Turbopump ATH 2303 M

Turbomolecular pump with large world wide installation base in light to harsh processes for DN 200 and DN 250 flange size.

- 5-axis magnetically levitated turbopump for maintenance-free operation
- Water cooled controller
- Operation in upside down orientation for dusty vacuum system
- Profibus interface (other fieldbus options available)

Pumping station CombiLine

For example, a combination of a Hepta 630 screw pump and an Okta 4000 Roots pump

- 600 m³/h dry roughing pump
- 4,000 m³/h Roots booster pump

Also available in various combinations, including wet and dry pumps.



ATH 2303 M



CombiLine

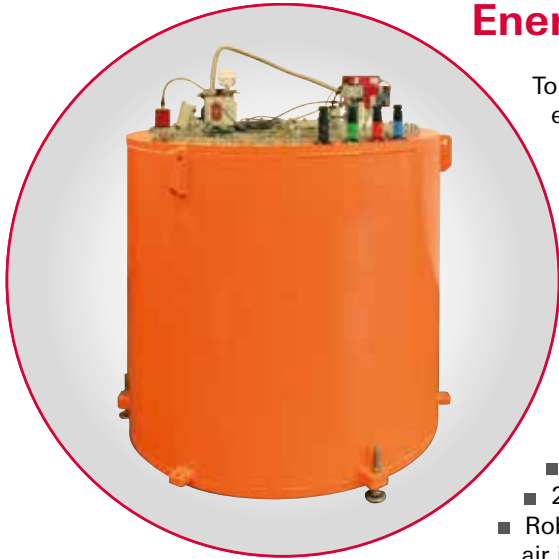

Energy storage flywheel

To ensure the efficiency of a flywheel as an energy storage device, the constant losses through friction have to be reduced to a minimum. To do so, the flywheel housing is evacuated with vacuum pumps. Typical targeted pressures are $1 \cdot 10^{-1}$ hPa down to $1 \cdot 10^{-3}$ hPa or even less.

Pfeiffer Vacuum products in use

Turbopump HiPace 300

- Compact yet powerful turbopumps with pumping speeds of up to 260 l/s for N₂
- Equipped with integrated power supply
- 24 VDC operation
- Robust enough to withstand accidental air inrushes

Rotary vane pump Duo 3 DC

Dual-stage, high-performance rotary vane pump with a pumping speed of 2.5 m³/h

- With 24 VDC drive
- Integrated gas ballast and safety valve
- Low cost of ownership due to power consumption < 100 W
- Low maintenance due to brushless drive and optional magnetic coupling
- Easy installation and small footprint

Pirani/cold cathode combination gauge MPT 200

With its rugged metallic case and digital interface, the MPT 200 is particularly suited for operation in vacuum and other systems.

- Display range: $5 \cdot 10^{-9}$ – 1,000 hPa
- Insensitive to gas inrush



HiPace 300



Duo 3 DC



MPT 200

Your Success. Our Passion.

We give our best for you every day –
worldwide!

Are you looking for your
optimized vacuum solution?
Please contact us:

Pfeiffer Vacuum GmbH
Germany
T +49 6441 802-0



All information is subject to change without prior notice. PT 0191 PEN (January 2022/PoD)

Follow us on social media
#pfeiffervacuum



www.pfeiffer-vacuum.com

PFEIFFER  **VACUUM**