



ATH 2804 M AND ATH 3204 M

Compact, magnetically levitated turbopumps in the pumping speed class of 3,000 l/s

ATH 2804 M AND ATH 3204 M

Compact, magnetically levitated turbopumps in the pumping speed class of 3,000 l/s

High gas throughput	The new ATH M pumps offer a gas throughput of over 5,000 sccm of nitrogen for non-heated applications. They also allow the highest throughput on the market with up to 1,500 sccm of argon and a pump operating temperature of 65 °C in corrosive applications.
High temperature operation	The pumps operate at high temperatures up to 85 °C (MT version) for use in the most aggressive applications with by-product deposition sensitive processes.
Compact	The newest generation of ATH M pumps includes integrated drive electronics to ensure a small footprint and easy plug-and-play installation. The total height of the DN 320 flange model is less than 400 mm. Due to the new electronics, the pumps can be started and stopped within 8 minutes.
5-axis magnetic levitation	Active magnetically levitated bearings enable wear-free, low vibration operation with an automatic out-of-balance compensation. They are maintenance-free and require no lubrication. Continuous rotor stability is assured for reliable performance.
Energy saving	Low power consumption at nominal speed and the lowest cooling water consumption (1 l/min) of their class also characterize the new ATH M pumps.

Customer benefits

- High gas throughput and high temperature operation required in harsh applications
- Tolerates exhaust pressure up to 3.4 mbar
- Low vibration operation with an automatic out-of-balance compensation
- Compact foot print to save variable space in a tool
- Integrated drive electronics for a wide range of applications
- Simple installation and easy start-up
- Energy saving – low electricity and cooling water consumption

Pumping speed

N_2 ———
 He ———
 H_2 ———
 Ar ———

ATH 2804 M/MT

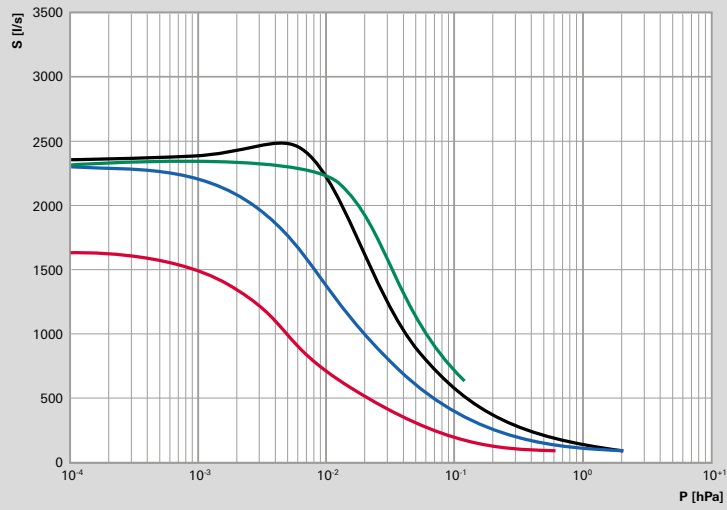

ATH 3204 M/MT

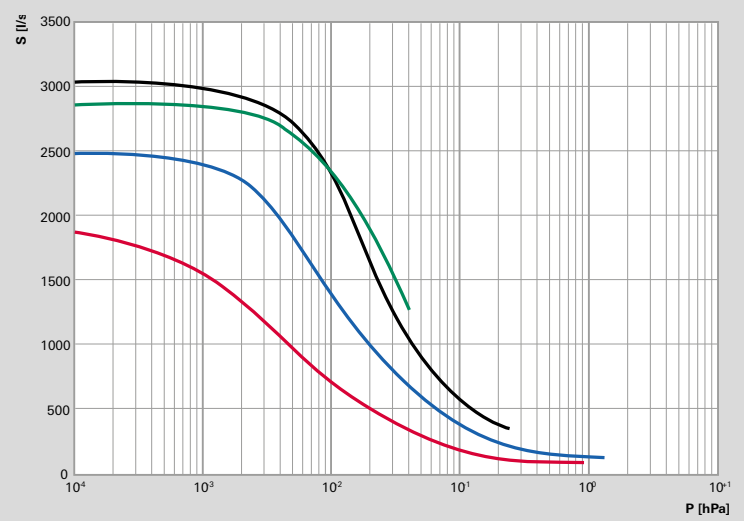

Dimensions

ATH 2804 M/MT

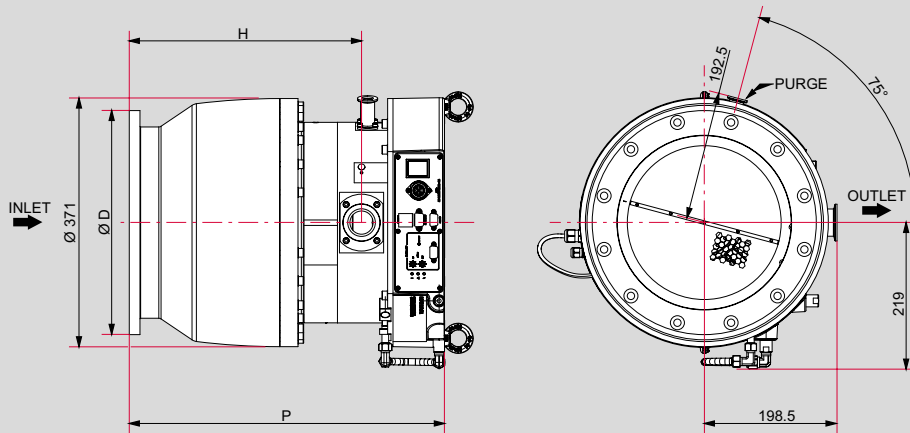

	ATH 2804 M	ATH 2804 MT
D	335 mm	335 mm
H	347 mm	300 mm
P	471 mm	471 mm

ATH 3204 M/MT

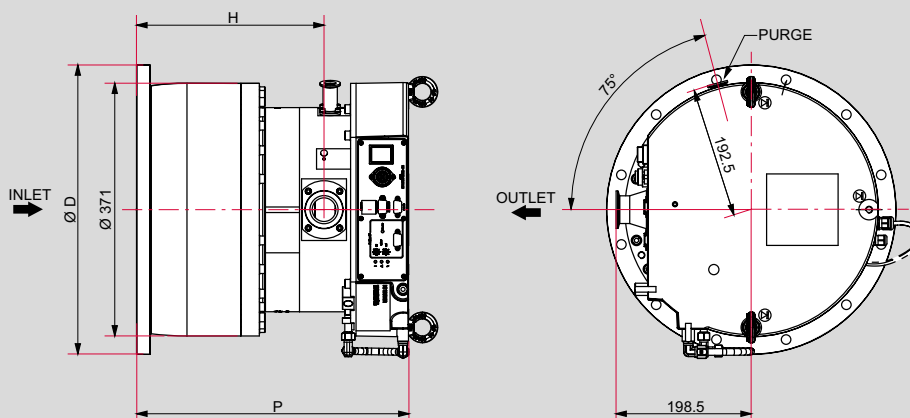

	ATH 3204 M	ATH 3204 MT
D	425 mm	425 mm
H	275 mm	228 mm
P	400 mm	400 mm

Dimensions in mm

Gas throughput

ATH 2804 M/MT /
ATH 3204 M/MT

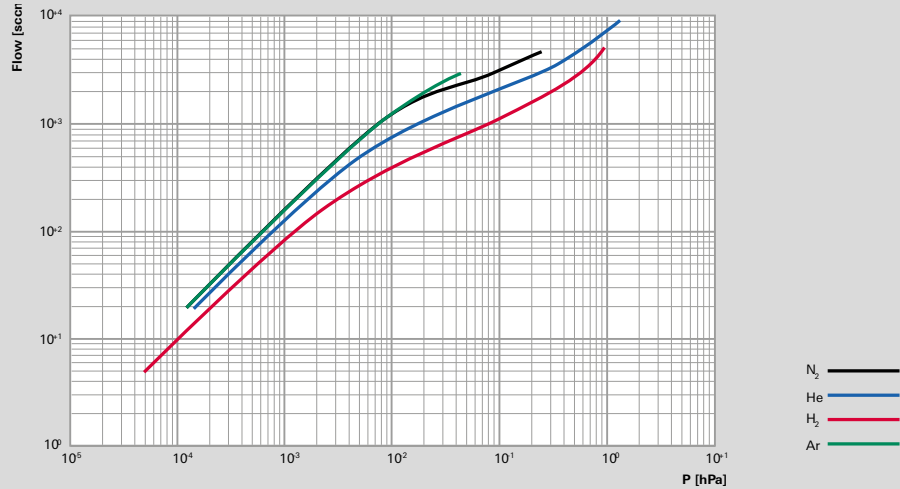

Technical data

	ATH 2804 M/MT	ATH 3204 M/MT
Flange (in)	DN 250 ISO-F	DN 320 ISO-F
Flange (out)	DN 40 / 50 ISO-KF	
Pumping speed for N ₂	2,350 l/s	3,050 l/s
Pumping speed for Ar	2,350 l/s	2,900 l/s
Pumping speed for He	2,300 l/s	2,500 l/s
Pumping speed for H ₂	1,650 l/s	1,700 l/s
Rotation speed ±2%	25,000 min ⁻¹	
Run-up time	< 8 min	
Gas throughput at full rotational speed for Ar	41.6 hPa l/s / 2,500 sccm	
Gas throughput at full rotational speed for H ₂	> 100 hPa l/s / > 6,000 sccm	
Gas throughput at full rotational speed for He	> 100 hPa l/s / > 6,000 sccm	
Gas throughput at full rotational speed for N ₂	83.3 hPa l/s / 5,000 sccm	
Compression ratio for N ₂	> 1 · 10 ⁸	
Compression ratio for Ar	> 1 · 10 ⁹	
Compression ratio for He	9 · 10 ⁴	
Compression ratio for H ₂	4.9 · 10 ³	
Fore-vacuum max for N ₂	3.4 hPa	3 hPa
Ultimate pressure according to PNEUROP	< 6 · 10 ⁻⁹ hPa	
Weight ¹⁾	98 kg (101 kg)	80 kg (103 kg)
Cooling method	Water	
Cooling water consumption	1 l/min	
Cooling water temperature	15–25 °C	
Interfaces	Remote	
Protection categorie	IP 54	
Sound pressure level	≤ 45 dB (A)	
Bearing	5 axe magnetically levitated	
Electronic drive unit	Integrated drive electronics	
Mounting orientation	in any orientation	
Operating voltage	220–240 V AC; 50/60 Hz, single phase	
Power consumption at ultimate pressure ¹⁾	< 160 W (590 W)	

¹⁾ Values in brackets = MT version

Order numbers

Order number	ATH 2804	ATH 3204
M version	TMAAA662015A	TMAAAC62015A
MT version	TMAAA6661101	TMAAAC661101



VACUUM SOLUTIONS FROM A SINGLE SOURCE

Pfeiffer Vacuum stands for innovative and custom vacuum solutions worldwide, technological perfection, competent advice and reliable service.

COMPLETE RANGE OF PRODUCTS

From a single component to complex systems:

We are the only supplier of vacuum technology that provides a complete product portfolio.

COMPETENCE IN THEORY AND PRACTICE

Benefit from our know-how and our portfolio of training opportunities!

We support you with your plant layout and provide first-class on-site service worldwide.

Are you looking for a
perfect vacuum solution?
Please contact us:

Pfeiffer Vacuum GmbH
Headquarters · Germany
T +49 6441 802-0

www.pfeiffer-vacuum.com