



ASM 340

Best-in-class leak detectors for fast, accurate and high reliability testing



ASM 340

Best-in-class leak detectors for fast, accurate and high reliability testing

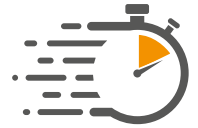

**Fastest test time
in its class**

Your added value



**Capable for both
vacuum and
sniffing tests**

Top performance in vacuum and sniffing leak detection

The ASM 340 guarantees top performance in vacuum and sniffing leak detection for various industries, from maintenance functions to applications in production environments. This dependable leak detector can be used both for qualitative leak localization as well as quantitative measurement of leak rate. The ASM 340 is characterized by its reliable and powerful pumping system and is available in oil sealed or dry versions.

Accurate measurement and short test time

All models provide accurate measurement and short test time thanks to high pumping speed. This makes them the ideal tool to get an optimized pump down time on test objects. High sensitivity, ultrafast response time and short recovery time are among the outstanding features of this compact multipurpose unit. Additionally, with its unrivalled performance in sniffing, the ASM 340 will be a great partner for leak localization on pressurized parts.

Customized for your individual needs

The ASM 340 is also available without backing pump, which allows the connection of other backing pumps in order to better adapt to your needs, e.g. when integrating into a leak detection system. In addition, all models of the ASM 340 series can be equipped with communication options. A complete range is available, from I/O to fieldbus options.



**Proven vacuum technology
components for high reliability
and low maintenance**



**Easy and intuitive
operation**

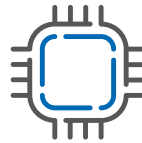

**Complete range of
communication interfaces**

Easy operation and smart functions

The control panel is equipped with a large, bright and high-resolution color touch display, offering a new user experience. Therefore, no training for handling the ASM 340 is required. The configuration of your leak test is directly accessible on the main screen and the color management of the display improves the readability of the test results. The control panel is detachable with integrated magnets, improving ergonomics for leak detection in medium or large size parts.

User-friendly post-processing of test data

The ASM 340 offers the possibility to document your test reports. The data can be recorded and stored in the internal memory as bitmap or text files, ready to be transferred on an USB stick via a dedicated USB output.

Extended range of accessories

For even more versatility, an extended range of accessories is available to cover a wide variety of applications. When leak testing large objects, the wireless remote control RC10 can operate the leak detector remotely and display the test results. Sniffer probes with different hose length and tip sizes as well as dust filters with various mesh sizes are also available. In addition, dedicated carts have been designed to bring mobility to the ASM 340.

ASM 340

Details and dimensions



ASM 340 – Measurement mode



ASM 340 – Standby mode



ASM 340 – Detachable screen



ASM 340 and RC10 remote control accessory

Dimensions

ASM 340

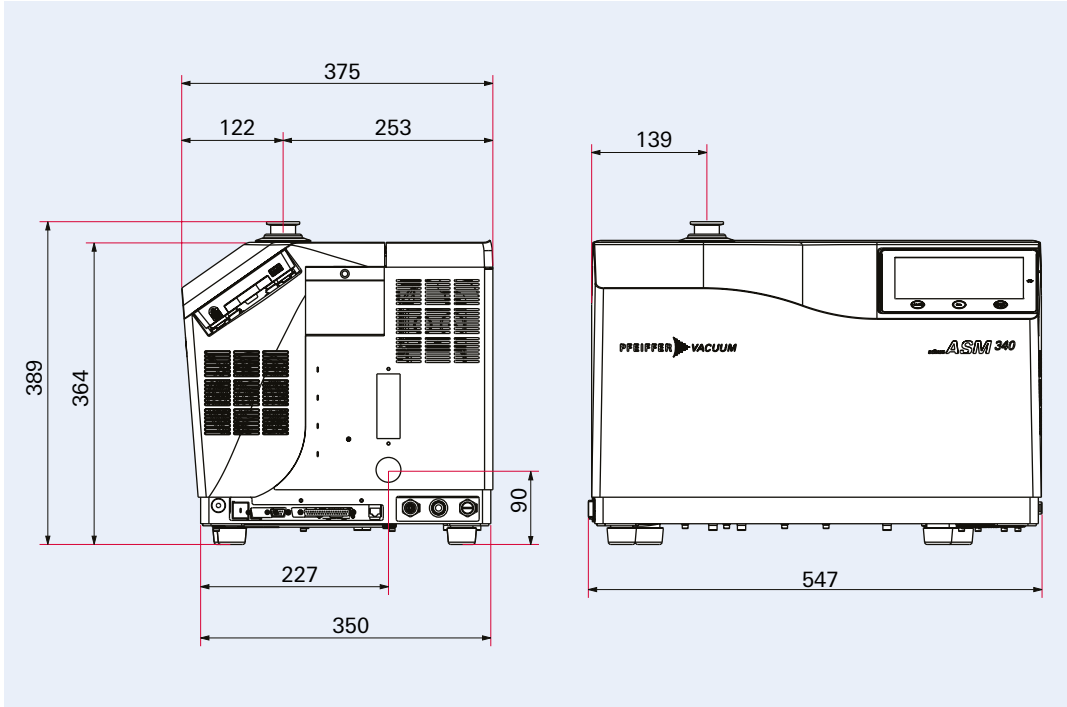

Dimensions in mm

ASM 340

Technical data, accessories,
order number matrix

ASM 340

$1 \cdot 10^{-12}$ mbar · l/s

Minimum detectable
leak rate for He
(vacuum leak detection)

< 1 s

Response time
(sniffing leak detection)



General technical data

	ASM 340
Test methods	Vacuum and sniffing
Minimum detectable leak rate for He (vacuum leak detection)	$1 \cdot 10^{-12}$ mbar · l/s
Minimum detectable leak rate for He (sniffing leak detection)	$5 \cdot 10^{-9}$ mbar · l/s
Tracer gases	^4He , ^3He , H_2
Response time (sniffing leak detection)	< 1 s
Maximum inlet test pressure	25 mbar
Pumping speed for He	2.5 l/s
Inlet port	DN 25 ISO KF
Start-up time (20°C)	3 min
Response time (sniffing leak detection)	< 1 s
Interfaces (see ordering matrix)	RS-232, I/O, USB, Fieldbus
Dimensions (LxWxH)	547 x 375 x 389 mm (14 x 10 x 16 inches)
Selectable languages	English, French, German, Italian, Spanish, Portuguese, Russian, Japanese, Chinese, Korean

Specific technical data

	ASM 340	ASM340 D (dry version)	ASM340 I
Backing pump	Rotary vane pump	Diaphragm pump	None
Roughing capacity	15 m ³ /h	3.4 m ³ /h	-
Weight	56 kg	45 kg	32 kg
Supply	100–110 V, 50/60 Hz 200–240 V, 50/60 Hz	Universal 100–240 V, 50/60 Hz	Universal 100–240 V, 50/60 Hz
Max. power consumption	850 W	600 W	350 W
Operating temperature	0–45 °C (vacuum) 0–40 °C (sniffing)	0–35 °C	0–40 °C

Order number matrix ASM 340

abcA02AdMe9f

Leak detector	abc
ASM 340	JSV
ASM 340 D (dry version)	KSB
ASM 340 I (without backing pump)	MSX

Interface board	d
Basic 15 Pins I/O	0
Basic 15 Pins I/O + Bluetooth	1
37 Pins I/O	2
37 Pins I/O + Ethernet ¹⁾	4
37 Pins I/O + Bluetooth	5
Profibus	8
Profinet	9

Supply	e
100–110 V; 50/60 Hz, US Power cable (only for ASM 340)	L
200–240 V; 50/60 Hz, EU Power cable (only for ASM 340)	H
Universal 100–240 V; 50/60 Hz (only for ASM 340 D + I)	M

Personalization	f
No	A
Japan (not available for ASM 340 D and ASM 340 I / supply voltage 90–130 V 50/60 Hz)	B

¹⁾ Ethernet will allow to create an additional COM port to operate the leak detector through a computer

Accessories

Accessories	Order number
Country specific power cables	
UK	104411
Italy	104758
Switzerland	103718
Sniffer probe	
5 m hose length, rigid 9 cm nozzle	SNC1E1T1
5 m hose length, rigid 30 cm nozzle	SNC1E2T1
10 m hose length, rigid 9 cm nozzle	SNC2E1T1
5 m hose length, flexible 45 cm nozzle	SNC1E4T1
Helium spray gun	
Standard	112535
“Elite-kit” spray gun with accessories in a compact case	109951
Remote control	
RC 10, wired/wireless	124193
Transport cart	
2 wheels trolley with large drawer (not for ASM 340 I)	122570
4 wheels trolley (upper plate dedicated to ASM 340 and lower plate for external backing pump)	On request
Inlet filters for dust	
Brass, 20 µm, DN25/25 ISO KF	105841
Stainless steel, 15 µm, DN25/25 ISO KF	127014
By-pass option	On request

Further accessories can be found on our website at www.pfeiffer-vacuum.com

Your Success. Our Passion.

We give our best for you every day –
worldwide!

Are you looking for an
optimal vacuum solution?
Please contact us:

Pfeiffer Vacuum GmbH
Germany
T +49 6441 802-0



Errors excepted. All data subject to change without prior notice. PL 0007 PDE (September 2022/PoD)

Follow us on social media
#pfeiffervacuum



www.pfeiffer-vacuum.com

PFEIFFER  **VACUUM**