

Leak Test Instrument Model E2 and Model VE2 Programming and Operation Manual

Hardware Revision A, C
7 July 2021
Manual Revision 2.3.13



INTRODUCTION

Proprietary Note:

The IGLS, Mass Extraction Technology, Adaptive Test and Leak-Tek ©, Leak-Rx© programs are proprietary products belong to PFEIFFER-VACUUM, Inc. and are protected by existing patents (5,861,546; 6,3085,56B1; 6,584,828B; ,6,854,318B2; 7,231,811,EP1-356-260-B1) as well as other US and International pending patents. The Leak-Tek program©, Leak-Rx© program, Adaptive Test Utility Program© and PFEIFFER-VACUUM Model-E2/VE2 are protected by international copyright laws.

© 1995-2014 PFEIFFER-VACUUM, Inc. All rights reserved.

This manual should not be copied or transferred to any third party without PFEIFFER-VACUUM's written consent.

(Revision 2.3.9 includes updates of RoHS declaration and company logo)

INTRODUCTION

TABLE OF CONTENTS

TABLE OF FIGURES	5
1.1 PRINCIPLE OF OPERATION	10
2. FUNCTION CONFIGURATION.....	11
2.1 FLOW MEASUREMENT.....	11
2.2 CONVENTIONAL LEAK TEST	12
2.3 MASS EXTRACTION METHOD TEST	12
2.4 FLOW MEASUREMENT WITH FLOW CONTROL.....	12
2.5 ADAPTIVE LEAK TEST.....	12
3. INTERFACE	13
3.1 MECHANICAL INTERFACE AND CONNECTION OF THE MODEL E2 OR MODEL VE2:.....	13
3.2 ELECTRICAL INTERFACE AND CONNECTION:.....	17
3.3 GUIDELINE FOR PNEUMATIC INTERFACE	22
3.4 GUIDELINE FOR FIXTURE DESIGN	23
3.5 GUIDELINE FOR SETTING UP MODEL E2 OR MODEL VE2 LEAK TESTER	26
3.6 VERIFICATION PROCEDURE.....	27
4. IGLS-MODEL E2 OR MODEL VE2 OPERATION SEQUENCE	28
5. GRAPHIC LCD DISPLAY & TOUCH SCREEN	30
6. COMMUNICATION PROTOCOL	34
6.1 CONVENTIONAL COMMANDS FOR SENSOR PARAMETERS	34
6.2 DAQ COMMANDS	34
6.3 STEP NUMBER.....	39
7. MAINTENANCE AND TROUBLESHOOTING	41
7.1 PERIODIC MAINTENANCE AND CALIBRATION	41
7.1.1 Filter.....	41
7.1.2 Periodic Calibration.....	41
7.1.3 System performance Verification.....	41
7.2 TROUBLESHOOTING	43
APPENDIX A - CALCULATION ALGORITHM.....	47
APPENDIX B - COMMAND LIST	50
B.1 A GROUP.....	50
B.2 B GROUP	50
B.3 C-GROUP.....	50
B.4 D GROUP	51
B.5 G GROUP.....	51
B.6 H GROUP.....	51
B.7 K GROUP.....	52
B.8 L GROUP	52
B.9 M GROUP	52
B.10 O GROUP.....	53
B.11 P GROUP.....	53
B.12 S GROUP.....	53
B.13 T GROUP	54
B.14 U-GROUP.....	54
B.15 V GROUP.....	57
B.16 X GROUP.....	58

INTRODUCTION

17 Y-GROUP	59
B.18 Z-GROUP	59
APPENDIX C QUICK REFERENCE FLOW SETTING PROCESS	60
APPENDIX D - SPECIFICATION SHEET	61
APPENDIX E - IGLS APPLICATION SETUP EXAMPLE.....	62
APPENDIX F – MODEL E2 OR MODEL VE2 ASSEMBLY DRAWING.....	63
APPENDIX G – MODEL E2 CONTROL ALGORITHM	67

TABLE OF FIGURES

FIGURE 3.1.1 - PNEUMATIC CONNECTION	15
FIGURE 3.2.1 – REAR PANEL STANDARD REMOTE I/O CONNECTIONS	19
FIGURE 3.2.2 – STANDARD REMOTE I/O PIN CONNECTOR.....	20
FIGURE 3.2.5 – LIST OF PASS AND FAILURE MODE WITH PIN OUTS	21
FIGURE 3.2.6 - SERIAL LOOP CONNECTION OF TWO MODEL E2 OR MODEL VE2 INSTRUMENTS	22
FIGURE 3.4.1: SURFACE SEAL DESIGN WITH STATIC O-RING.....	25
FIGURE 3.4.2 CHAMFER SEAL DESIGN USING O-RING.....	25
FIGURE 3.4.3 EXPANDABLE SEAL DESIGN	26
FIGURE 5.1 - MODEL “E2” OR “VE2” LCD	30
FIGURE 5.2 - MODEL “E2” OR “VE2” LCD ELEMENTS	32
FIGURE 5.3 - LCD DISPLAY WITH EXTERNAL PRESSURE SENSOR REPLACING INTERNAL PRESSURE SENSOR DISPLAY.....	33
FIGURE 6.1 - STEP NUMBER INTERPRETATION	40
FIGURE 7.2.1 - TROUBLESHOOTING	46
FIGURE D.1 - TEST TIME SETTING.....	62
FIGURE D.2 - PID COEFFICIENT	62
FIGURE D.3 - VALVE SETTING	62
FIGURE D.4 - PRESSURE SETTING	62
FIGURE D.5 - FLOW CRITERIA	62
FIGURE E.1 – MODEL E2 ASSEMBLY	63
FIGURE E.2 – MODEL VE2 ASSEMBLY	64
FIGURE F.1 LEAK TEST CONTROL ALGORITHM	67
FIGURE F.2 MASS EXTRACTION TEST CONTROL ALGORITHM	68

INTRODUCTION

WARNING:

This product deals with gas that will expand under pressure. Pressurized volumes (components, hoses, etc.) should be handled with proper protection to avoid any harm to the user.

WARNING:

This product is supplied with a power supply fed with 115 VAC or 220 VAC, single phase. When handling high voltage, use proper care to avoid harm to personnel and equipment due to electrical shock.

WARNING:

Leak Test Instruments sold to locations outside of North America will include a power cord that is intended for standard use in continental Europe. This cord is manufactured with a 230V IEC 7/7 Type F: "Schuko" plug. It is the responsibility of the Leak Test Instrument end user to ensure that this cord is adequate and appropriate for the intended use and complies with all applicable laws, regulations, codes and standards of the region where the Leak Test Instrument will be used. If not, the end user will need to source an appropriate power cord that meets their local requirements

WARNING:

Use this product for the purpose of leak testing or flow measurement and testing in the pressure ranges and temperature ranges specified, ONLY!

WARNING:

Only qualified personnel should install, or use this product. Installation must comply with the manual requirements and product specifications.

WARNING:

Under no circumstances while the test is on should the operator tamper with the "unit under test (UUT)". This may result in bodily injury and/or erroneous results.

WARNING:

This product shall be used for leak test applications and/or flow measurement applications only.

WARNING:

When this Leak Test Instrument is part of a leak test system, it is the user's responsibility to assure proper interface and maintenance in order for this instrument to utilize its measurement capabilities safely and accurately.

INTRODUCTION

WARNING:

This instrument should **NOT** be operated at a pressure greater than a *maximum of 160 psig or full scale of the sensor, whichever is lower.*

CAUTION:

This Leak Test Instrument measurement reflects the momentary leak flow rate of the unit under test as presented to this instrument, at the test conditions and environment used. It is not a guarantee for "leak-free" products over long periods of time that are used in a different condition and environment.

E.g. unit under test that is not dry and clean, and contains liquid or other particulates that can plug leak flow path which may pass the leak test but leak during actual usage.

CAUTION:

The user shall be familiar with flow, pressure and temperature measurement units before setting up the leak test instrument. It is the user's responsibility to properly define leak flow rates and tolerances for a specific application.



This product has been tested to the requirements of CAN/CSA-C22.2 No. 61010-1, second edition, including Amendment 1 or a later version of the same standard incorporating the same level of testing requirements.



Warning Marking ISO 7000 – 0434 is attached to the back panel of the product. Product documentation must be consulted for the product on why this symbol is marked.

La notice d'avertissement ISO 7000 – 0434 est fixée au panneau arrière de ce produit. La documentation du produit doit être consulté pour le produit sur lequel ce symbol est marqué."

NOTE: FUSE RATING

Cooper Bussmann GMC-2A (250V, 2A, Time Delay) Fuse should be used for over current protection.

NOTE: SAFETY CONFORMITY MARKING

THE SAFETY CONFORMITY MARKING IS APPLICABLE ONLY FOR INSTRUMENT PROPERLY MARKED WITH ETL, CE OR SIMILLAR MARKING.

EU DECLARATION OF CONFORMITY

1. Produce model / Product:

Product Micro-Flow Leak and Flow Test Instrument
Model/Type E2, VL2, RD21 and all variants/options associated with these models

2. Manufacturer:

Manufacturer Pfeiffer Vacuum Incorporated
Address 4037 Guion Lane
Indianapolis, IN 46268
317-328-8492
USA
www.pfeiffer-vacuum.com

3. This declaration of conformity is issued under the sole responsibility of the manufacturer.

4. Object of the declaration:

Product An electro mechanical instrument for detecting micro-flow leaks

5. The object of the declaration described above is in conformity with the relevant Union harmonization legislation:

2011/65/EU The Restriction of Hazardous Substances Directive
2014/30/EU The Electromagnetic Compatibility Directive
2014/35/EU The Low Voltage Directive

6. References to specifications in relation to which conformity is declared:

UL 61010-1: 2004 Safety Requirements for Electrical Equipment for Measurement, Control, and Laboratory Use
CSA 61010-1-04: 2004 Safety Requirements for Electrical Equipment for Measurement, Control, and Laboratory Use
EN 61326-1: 2006 Electrical equipment for measurement, control and laboratory use - EMC requirements

7. The technical file is available from the manufacturer at the address above

Signed for and on behalf of: Pfeiffer Vacuum Incorporated
Place of issue: USA
Date of issue: 14th June 2021
Name: Derek Izzi
Position: General Manager
Signature:



INTRODUCTION

1. Introduction

This manual applies to the operation and maintenance of the Leak Test Instrument Model E2 or Model VE2 incorporating the Intelligent Gas Leak System (IGLS).

The IGLS is a micro-flow gas sensor operating based on PFEIFFER-VACUUM's patented accelerated laminar flow design. The IGLS measures Volume Flow, Pressure and Temperature. Therefore, the instrument can display volume flow, mass flow or volume flow at std. conditions - by selecting one of 27 flow units and their combinations. The IGLS has a microprocessor-based flow computer and controller. The flow computer program performs on-board volumetric (i.e., cc/min) or mass (e.g., g/min) flow measurements, with temperature and pressure compensation. The flow computer can total the flow during (i.e. total mg) testing using the mass extraction concept. In addition, pressure control can be performed for the purpose of leak testing. The Intelligent Gas Leak Sensor (IGLS) has capabilities to control valve sequencing required for a complete stand-alone leak test.

The Model E2 or Model VE2 implements the valves needed for most leak testing applications using the IGLS. The touch screen graphic LCD display includes a start, stop and test select buttons, measurement reading and its line graph.

The IGLS measures leak flow rates based on the mass conservation law. It measures the amount of flow required to maintain constant pressure at a constant temperature equal to the amount of flow "leaking out". This method offers quick test time without sensitivity to unit under test volume.

A separate software (optional, and may not be included with this product) with a Graphical User Interface (GUI), the Leak-Tek® program, can be used in conjunction with the IGLS. The Leak-Tek program allows the user to configure desired parameters to meet specific requirements, and can be used to download to the IGLS as well as view, save, and analyze test data using a PC.

The IGLS receives commands and data requests, and returns data via a bi-directional RS-232 port. The Model E2 or Model VE2 includes a female 9-pin D-connector on the rear panel for connecting to a PC using a straight through RS-232 serial extension cable. Up to 9 IGLS and/or Model E2 or Model VE2 units can be attached to a single RS-232 port. The Model E2 or Model VE2 also includes an RJ45 Ethernet connector on the rear panel for connecting to a PC via a network connection either directly to a PC or through a LAN. Selection of the communication method is made via the COMM SELECT toggle switch located between the RS232 and Ethernet ports on the rear panel. Only one communications port may be used at any time. The Ethernet connection does not support multiple users access to the Model E2 or Model VE2. Refer to the

INTRODUCTION

Operator Manual for Leak-Tek © program version 5.0 or later for network setup and instrument configuration when using the Ethernet communications port.

Extensive programming commands allow the user to address any one of the connected sensors in order to configure the selected sensor, update the calibration data, and establish new test parameters.

The analog output is configured to 0-5V using an internal reference.

Depending on the Model type, the instrument can be configured to run up to four (4) types. Test type can be selected via the front panel graphic LCD display, or remotely via the rear panel connections.

All remote or external controls (input and output) are available at the male 37-pin D connector located on the rear panel of the Model E2 or Model VE2.

1.1 Principle of Operation

The Leak Test Instrument, Model E2 or Model VE2 and its accessories provide a complete solution for leak flow testing. The leak test concept is based on the mass conservation law. Per this basic law of physics, once the unit under test (UUT) is pressurized and reaches steady state condition (stable pressure and temperature), the amount of mass flow into the UUT equals the amount of mass flow that leaks out.

In other words, the IGLS measures the makeup flow required to keep the pressure steady in the UUT, under pressure condition. In vacuum (only applicable to Model VE2), the IGLS measures the mass flow extracted from the UUT, to maintain a steady vacuum condition.

The IGLS is a unique micro-flow sensor, capable of measuring extremely low flow, utilizing PFEIFFER-VACUUM's accelerated laminar flow design. The IGLS measures volume flow and converts it to mass flow based on pressure, temperature measurements and gas type. The IGLS sensitivity is further increased in vacuum condition, where a given mass flow yields in larger volume flow due to the reduced gas density at low pressure. The IGLS operates in the viscous and slip flow regimes, in pressure ranges of 13.8 kPa Absolute (~2 psia) to 1200 kPa Abs (175 psia).

When performing tests at low absolute pressure, or deeper vacuum (e.g., under 13.8 KPa absolute pressure) the material transfer mechanism varies. For these applications PFEIFFER-VACUUM's Mass Extraction Instrumentation with the Intelligent Molecular Flow Sensor (IMFS) should be used.

The advantage of the IGLS technology, or mass flow measurement is that the leak flow rate, at steady state, is independent of the UUT volume, and the measurement is a direct leak flow measurement.

INTRODUCTION

Therefore, frequent calibration is not required, and standard annual calibration procedures are applicable. The supplied verification orifice (sometimes called “calibrated leak”) is used only to verify equipment operation, such as valves leakage, ...etc.

The Model E2 or Model VE2 utilizes valves with fixed orifices; therefore, testing large volumes with this instrument may require longer fill time. For these applications consult PFEIFFER-VACUUM.

The IGLS technology offers faster and very repeatable leak tests. For shorter cycle time, you can use the signature concept, as described in the Leak-Tek© software manual.

2. Function Configuration

The IGLS/IGFS/IMFS can be used for several distinct applications as follows:

1. Flow Sensor/Standard for precision measurement of mass or volume flow for calibration purposes. (The Intelligent Gas Flow Standard/Sensor or IGFS/IMFS)
2. Conventional Leak Test: Automated leak testing with or without automatic pressure control. (The Intelligent Gas Leak System or IGLS)
3. Leak Testing using the mass extraction concept.
4. Flow Sensor with automatic flow control. (IGFS)
5. Adaptive Leak Test: Based on dynamic leak flow analysis, the sensor will detect the leak flow result at any time during the leak test period depending on the flow stability and leak detection criteria.

2.1 Flow Measurement

When being used as a flow sensor/standard, the IGFS will continuously sample the signals from its pressure, flow, and temperature sensors. Then it calculates volume flow or mass flow based on the calibration coefficients of sensors and test conditions. Analog output signals ranging from 0 V to 5 V is sent out in proportion to the flow depending on setup parameters. Readings are available via an RS-232 serial communications interface or Ethernet network interface.

Each IGFS/IGLS is calibrated by standards traceable to NIST. Three measurements of uncertainty ranges are available, from 10% to 100% of the sensor range, with 95% level of confidence. Setup parameters for specific gas types must be downloaded via the Leak-Tek © program or Gas-Cal © program or a regular Microsoft Windows™ hyper-terminal.

INTERFACE

Refer to the supplied specification sheet (Appendix B) for flow range, pressure and temperature ranges and specified accuracy.

2.2 Conventional Leak Test

When functioning as a conventional leak tester, the IGLS controls signals to the clamping valve, pressure valve, and fill valves to fill the unit under test (UUT) and allow stabilization.

After the stabilization time, the test begins. The IGLS will monitor flow readings for a pre-defined test time period and make a pass/fail determination based on pre-defined test criteria (pressure and flow must be within a pre-defined range to pass the test). The flow will automatically shut down if a pass occurs. The re-test function can be configured to allow a continuous test until the pass criteria are met. The test status is displayed on the LCD. Test pass/fail criteria, test time, and stabilization time are configurable via the RS-232 port or Ethernet port using the Leak-Tek © program or hyper-terminal.

Refer to Appendix C for application examples. If the multiple-test feature is configured, it is possible to toggle between multiple test types.

2.3 Mass Extraction Method Test

In some situations, the leak may not be constant, may vary significantly during the test, or the UUT is a sealed volume, which cannot be pressurized. Therefore the mass extraction method would be the valid test method. It accumulates (totals over test time) the leaks during the test period, and compares to the maximum setting to make a decision of pass or fail.

In many cases, Mass extraction will be performed while the part is inserted into a sealed chamber, vacuum is applied into the chamber and the Model VE2 is located between the vacuum source and the chamber.

2.4 Flow Measurement with Flow Control

The IGFS can be used as a precision flow sensor and controller. The IGFS measures flow and pressure, and uses its analog output channel to control the remote flow control valve. The analog output is configured to be 0-5 VDC. The flow setting can be either in volumetric or mass flow based on the flow unit selection. Consult PFEIFFER-VACUUM before doing this.

2.5 Adaptive Leak Test

If the leak rate of the majority of tests for the UUT is much smaller than the leak tolerance, then the user can configure the sensor to dynamically analyze the flow behavior, and make an early detection to determine if the leak rate is going to be significantly smaller or larger than the leak tolerance. In most cases, this will significantly reduce the total test time.

3. Interface

3.1 MECHANICAL INTERFACE AND CONNECTION of the Model E2 or Model VE2:

WARNING:

If hazardous conditions and gasses result, consult PFEIFFER-VACUUM. The standard Model E2 or Model VE2 is NOT rated to operate in class 1 or 2 environments.

WARNING:

The fluids used should be gasses compatible with IGLS wetted material, which consists of stainless steel and viton seals. Gasses currently supported are dry air, nitrogen, carbon dioxide, and helium. For other gases, consult PFEIFFER-VACUUM.

CAUTION:

The Model E2 or Model VE2 is supplied with a filter. Clean and maintain the filter and supply lines, as excessive contamination will cause distortion of readings.

CAUTION:

The operating temperature as well as the gas temperature should be from 10 to 45 °C. For a higher temperature range, consult PFEIFFER-VACUUM.

CAUTION:

Connections of instrument ports should be per the enclosed schematics. Support all bulkhead fittings with proper wrenches to hold those connections steady, and to avoid internal damage to the instrument. Follow Swagelok ® fitting assembly instructions. While assembling Model E2 or Model VE2 use two wrenches. Support bulk head fittings with proper backup wrench.

The Model E2 or Model VE2 can be mounted on a bench top, as supplied with four rubber pads. Alternatively, it can be mounted on a shelf above or below the test unit/fixture and secured with four bolts, replacing the rubber pad bolts.

CAUTION:

The Model E2 or Model VE2 needs to be mounted flat relative to the horizontal plane for the sensor to work properly.

NOTE:

Mount and locate the Model E2 or Model VE2 as close as possible to the UUT to minimize Model E2 or Model VE2 UUT connection tube length and volume. Larger volume will reduce system response to a given leak flow.

The Model E2 or Model VE2 controls an internal fill valve, an isolation valve, and a pressure/test valve, as well as an optional external exhaust valve, clamp/seal valve and/or electronic pressure controller. Solenoid valves are used for automatic control. A calibrated leak solenoid valve can be operated from the front

INTERFACE

panel controls. The pneumatic connection should be per the enclosed diagram (Figure 3.1.1).

Optimize inlet pressure expansion size. Expansion tank should be 10 times larger than UUT volume, if possible. However, an expansion tank between the pressure regulator/controller and the Model E2 or Model VE2 will reduce pressure fluctuations, and increase system performance. An isolation valve is required for smaller and medium leak rates. The isolation valve isolates the Model E2 or Model VE2 from the supply line during the measurement cycle (stability and test time).

The pressure supply to the Model E2 or Model VE2 must be very stable. Air tools connected to the same line may cause a shock wave that will affect pressure stability. If the Model E2 inlet pressure “drops” during the test, the flow will reverse, and the Model E2 will display zero flow which may cause measurement bias (the reverse happens for the model VE2). Supply pressure should be stable within 1 inch of water during stability and test time.

Furthermore- if during pressure (not vacuum) leak test, the inlet pressure drops more than 30 psig, a gross leak may be experienced due to quick-fill valve inability to seal. Therefore, PFEIFFER-VACUUM’ pressure regulators (options 5 or 5A) are recommended. If you experience intermediate pressure drops during leak test, a buffer tank is recommended upstream to the pressure regulator. The size of such buffer tank should be similar to the Expansion tank used as part of the leak test circuit (figure 3.1.1).

Similar consideration should be applied during Mass Extraction (vacuum) leak test with the model VE2. PFEIFFER-VACUUM Vacuum generation and control package is recommended for these applications (options 12A; 12B; 12C)

Optimize tubes/hoses/valves sizes to get desired test times.

INTERFACE

Supply Pressure and expansion tank connections: these connections are in the back of the instrument. Support the bulkhead fitting with 5/8" wrench (3/4" for Vacuum) when tightening the tube fitting (1/4" Swagelok ® tube fitting). Do not over-tighten.

INTERFACE

3.2 ELECTRICAL INTERFACE AND CONNECTION:

The Model E2 or Model VE2 is supplied with a power cord for 115-VAC single-phase power. Connect it to an AC connector that complies with local electrical codes.

Units with 220-VAC single-phase operation are available by special order.

The Model E2 and Model VE2 units are rated as shown in Table 3.2.1

Voltage	Current	Power	Frequency
120 VAC	0.94 A	113 W	50/60 Hz
220 VAC	0.46 A	101 W	50/60 Hz

TABLE 3.2.1

WARNING:

The Model E2 or Model VE2 is supplied with a power cord, connected to 115VAC or 220VAC single-phase connector. Proper grounding and electrical practices should be used. When maintaining, or opening the Model E2 or Model VE2 enclosure, the supplied power should be disconnected!

CAUTION:

Improper power wiring will cause permanent damage to the unit. Always observe hot and neutral polarities when connecting to AC power source. Never connect a 115-VAC unit to a 220-VAC source, or vice versa.

NOTE:

All digital inputs are optically isolated. Use only correctly rated voltage for inputs.

NOTE:

Digital outputs are not designed to drive an inductive load. Use small external relays or optically isolated modules (preferred) to drive valves or large relays.

NOTE:

The Model E2 or Model VE2 Ethernet port does not support Power Over Ethernet (POE).

NOTE: The Model E2 and VE2 use a 2A fuse for the power module (example: Buss PN: BK/GMC-2-R) and 500A buss fuse for the E2 RD21 board (example: Buss: PN: BK/GMC-500-R)

The remote I/O connectors located on the rear panel of the Model E2 or Model VE2 is arranged as shown in Figures 3.2.1 & 3.2.2. See Appendix F for wire instructions on PNP and NPN.

INTERFACE

Pin	Function	Specifications
Pin 1	Analog Output A	0-5 VDC
Pin 2	Analog Output B	0-5 VDC
Pin 3	Remote Exhaust Valve Output	Switched 12 VDC, 22W max
Pin 4	Remote Exhaust Valve Return	0 VDC
Pin 5	Ground/Common	0 VDC
Pin 6	Verify Input	5-30 VDC, source or sink*, 30 mA max.
Pin 7	Remote Output Common	5-30 VDC, source or sink*, 100 mA max.
Pin 8	Clamp Output	5-30 VDC, source or sink*, 100 mA max.
Pin 9	Pressure/Test Output	5-30 VDC, source or sink*, 100 mA max.
Pin 10	Exhaust Output	5-30 VDC, source or sink*, 100 mA max.
Pin 11	Fill/Balance Output	5-30 VDC, source or sink*, 100 mA max.
Pin 12	Quick Fill Output	5-30 VDC, source or sink*, 100 mA max.
Pin 13	Isolate Output	5-30 VDC, source or sink*, 100 mA max.
Pin 14	Analog Ground	0 VDC
Pin 15	Not used	
Pin 16	Not used	
Pin 17	Not used	
Pin 18	Not used	
Pin 19	Not used	
Pin 20	Not used	
Pin 21	Custom2 Output	5-30 VDC, source or sink*, 100 mA max.
Pin 22	Pass Output	5-30 VDC, source or sink*, 100 mA max.
Pin 23	Fail Output	5-30 VDC, source or sink*, 100 mA max.
Pin 24	PFail Output	5-30 VDC, source or sink*, 100 mA max.
Pin 25	TTA Output	5-30 VDC, source or sink*, 100 mA max.
Pin 26	TTB Output	5-30 VDC, source or sink*, 100 mA max. Test Type1: TTA:1, TTB: 0 Test Type2: TTA:0, TTB: 1 Test Type3: TTA:1, TTB: 1 Test Type4: TTA:0, TTB: 0

INTERFACE

Pin 27	Start Input	5-30 VDC, source or sink*, 30 mA max. Apply a pulse to the sensor Start input pin to start a test
Pin 28	Stop Input	5-30 VDC, source or sink*, 30 mA max. Apply a pulse to the sensor Stop input pin to stop a test
Pin 29	Test Type Input	5-30 VDC, source or sink*, 30 mA max. Apply a pulse to the sensor Test Type input pin to switch to the other test type
Pin 30	Pressure Switch Input	5-30 VDC, source or sink*, 30 mA max.
Pin 31	Remote Input Common	5-30 VDC
Pin 32	Not used	
Pin 33	Not used	
Pin 34	Not used	
Pin 35	Not used	
Pin 36	Not used	
Pin 37	+5 VDC Power (DO NOT use to power external devices! Use only for Model E2 or Model VE2 digital inputs.)	+5 VDC
* Sinking or Sourcing is selected for all Inputs or Outputs as a group, i.e. all sinking inputs, all sourcing outputs, etc. Use pins 7 and 31 to select type and voltage of inputs and outputs.		

Figure 3.2.1 – Rear Panel Standard Remote I/O Connections

* If other custom options are purchased, see the drawings section in the back of this manual.

INTERFACE

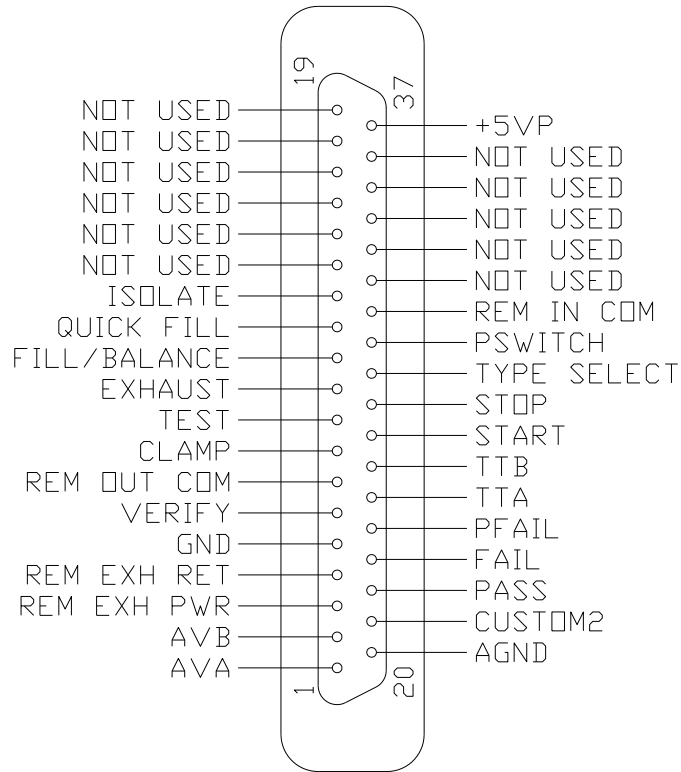

Figure 3.2.2 – Standard Remote I/O Pin Connector

Condition	Description	Pin out
Pass	The test met all criteria set in the set up screen	Pin 22
Gross leak Fail	Pressure is below the Pressure Min setting in pressure testing	Pin 23
Gross leak vacuum Fail	Pressure is larger than the Pressure Max setting in vacuum testing	Pin 23
No Pres Fail	Pressure switch not turned on in time.	Pin 23
Blockage Fail	Pressure switch not turned off at the end of the test during deplete time, External Pressure is within the limits for Ext Press Off action	Pin 23, Pin 24
Large Leak Fail	The Flow is more than the large leak setting	Pin 23
Hi Flow Relative	Relative Measurement Base	Pin 23

INTERFACE

Measurement Fail	Line Flow larger than the set point	
Lo Flow Relative Measurement Fail	Relative Measurement Base Line Flow Lower than the set point	Pin 23
Fine Leak Fail	Flow is above the maximum flow limit setting	Pin 23
Low Flow Fail	Flow is below the minimum flow limit setting	Pin 23
Back Flow/Sys pass	The Flow Sensor Detected the Flow in Opposite Direction or System leak check failure	Pin 23
Over pressure	The Pressure Is Larger Than The Pressure Max Setting in pressure testing	Pin 23
Under pressure	The Pressure is below the Pressure Min Setting in vacuum testing	Pin 23
Flow Saturation	Exceeding Flow Sensor Limit	Pin 23
Pressure saturation	Exceeding press Sensor Limit	Pin 23
Temperature saturation	Exceeding temperature Sensor Limit	Pin 23
PresRng-HI	External Pressure higher than set limit	Pin 23, Pin 24
PresRng-Lo	External Pressure Lower than set limit	Pin 23, Pin 24

Figure 3.2.5 – List of Pass and Failure Mode With Pin outs

Up to 9 Model E2 or Model VE2 instruments can be connected in a serial loop. A typical serial loop connection with two instruments is shown in Figure 3.2.6.

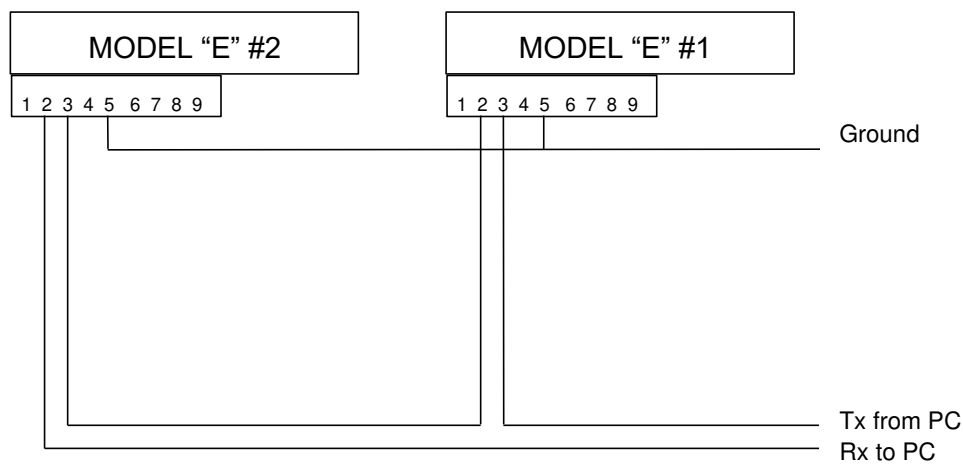

INTERFACE

Figure 3.2.6 - Serial Loop Connection of two Model E2 or Model VE2 Instruments

* See DRAWINGS section at the end of the manual for details of Option connections.

See appendices for sample PLC program for remote automatic operation of the Model E2 or Model VE2.

3.3 Guideline For Pneumatic Interface

1.0 Purpose:

Proper pneumatic interface is important to assure repeatable, reliable and safe leak testing. Supply pressure fluctuations must be minimized to PFEIFFER-VACUUM's supplied regulator, in order to assure good system performance. Most pressure regulators respond to line pressure spikes, and this may cause variability in the test results.

Proper connections must be used to minimize system leaks and reduce virtual leaks (leaks that flow into internal hidden cavities).

2.0 Common Rules:

Upstream pressure fluctuations from pneumatic actuators and/or assembly tools are undesirable, as they will affect precision pressure regulators and cause pressure/flow fluctuations that are uncontrollable. Therefore, a separate air supply line is required. If common supply is used, a large expansion tank is required.

- 2.1 Air must be clean (10 micron filter) and dry (descent dryer) to protect the valves, and to assure that a pinhole leak is not masked up.
- 2.2 Two regulators, especially precision ones, back to back will experience pressure ripple. Therefore, a volume must exist between two adjacent pressure regulators. Include an expansion tank or use two separate feed lines.
- 2.3 No NPT or "push-in" fittings at test lines. If NPT must be used, consult PFEIFFER-VACUUM.
- 2.4 Recommended fittings: stainless steel Swagelok® or Parker (A-lok)®. Use one or the other. Do not mix.
- 2.5 Use VCO or VCR fittings for low leak specification test applications and vacuum applications (Mass Extraction), to minimize virtual leaks.

3.0 Leak Testing pressure supply requirements:

- 3.1 High-pressure coarse regulator with volume (expansion tank) is recommended before PFEIFFER-VACUUM's supplied precision pressure regulator. Pressure shall be set higher than the test pressure, for quicker regulator response, as long as it does not

INTERFACE

exceed the regulator ratings. Pfeiffer-Vacuum typically will supply the precision pressure regulator and the test circuit expansion tank.

Note: If upstream regulator and expansion tanks are user supplied, consult Pfeiffer-Vacuum.

4.0 Blockage/Flow Test (where applicable):

- 4.1 The test is performed at a very low pressure (few inches of water).
- 4.2 Upstream regulator (coarse) set to 20 psig is required, prior to Pfeiffer-Vacuum's precision regulation and electronic pressure controller.
- 4.3 Dry clean air is required. Filter and dryer should not restrict flow.
- 4.4 A remote pressure transducer that helps to compensate for pressure loss at connecting tube to the UUT should be mounted as close as possible to the test inlet.
- 4.5 Connection lines are typically 1/2" or 3/4" (application dependent, TBD).

3.4 Guideline for fixture design

The following are recommendations regarding fixture design using Pfeiffer-Vacuum's leak test instruments and low-level leak testing. This is only a recommended guideline, based on Pfeiffer-Vacuum's prior experience using third party fixtures.

Note:

It is the user's responsibility to properly design the test fixture, test fixture control, electrical system and pneumatic interface for proper leak testing operation.

Caution:

Duplication of fixtures operating with under water or pressure decay leak test methods can result in lack of performance using Pfeiffer-Vacuum's micro-flow leak test methods, especially at low level leak testing.
--

Warning:

Fixture design and operation should comply with all safety requirements, especially when performing pressure tests. High forces can be easily generated with relative low pressure, but large sealing area.

- Assure that all safety aspects are per code and in place, during the fixture design, build and application. Assure operator and maintenance personnel safety.
- Mechanical fixture should provide stable volume. Fixture seal "drift" or movement during leak test will cause volume changes and bias of readings.
- Fixture and seal plate should be designed to have metal-to-metal contact with the unit under test, to prevent seal movement during test. Avoid adjustments that can drift or be tampered with (Figure 1 and 2).
- Seal mechanism should fit the application. For low leak rate applications, an O-ring seal design (inside a dovetail groove. Figure 1) approach should be

INTERFACE

considered. It requires tight true positioning of the sealing surfaces. Follow the O-ring “squeeze” requirements of the manufacturer.

- Note: Do not use double O-rings or seals. One seal, properly designed is all that is required. The second seal causes virtual leaks.
- Note: gasket seals are not recommended for a tight leak specification due to the potential of virtual leaks.
- Seal holders should have positive metal stops that are consistent. Seals should have proper relief to minimize virtual leaks.
- Sealing material should fit the application. For high wear applications, polyurethane and natural rubber can be considered.
- Expandable seals must be properly designed (see example in figure 3). When using commercially available expandable seals that are pneumatically driven, make sure that an air leak from the actuating cylinder cannot get into the test volume (leaking into the UUT or vacuum chamber) as this will bias the leak test results! Expandable seals must have means to stop seal “creep” during test. Using the unit under test as a hard stop is always preferred.
- Fixture design should support the part to prevent expansion during actual leak test. This is applicable to flexible products such as polyethylene packages.
- Minimize fixture volume or add filler for UUT with large cavities in order to minimize test setup volume (see figures 1,2,3). The larger the volume the slower a given leak flow will develop. Filler must be made out of solid machined material, casting or molded filler risk porosity and virtual leaks.

Be aware of “virtual leaks” for leak tests with tight leak flow specifications. Virtual Leaks are “hidden cavities” in the part and test fixture, which will take longer times to charge with pressure or to evacuate. It will also take longer times to deplete the pressure at the end of the test. Virtual leaks may look like “leaks” as they consume air to charge them. Virtual leaks will cause test cycle times to be longer (in order to charge the parts) and require sufficient time between consecutive tests to deplete or recharge the UUT pressure. Insufficient time between consecutive tests will result in poor test repeatability.

Design your test fixture and sealing mechanism to minimize virtual leaks!

INTERFACE

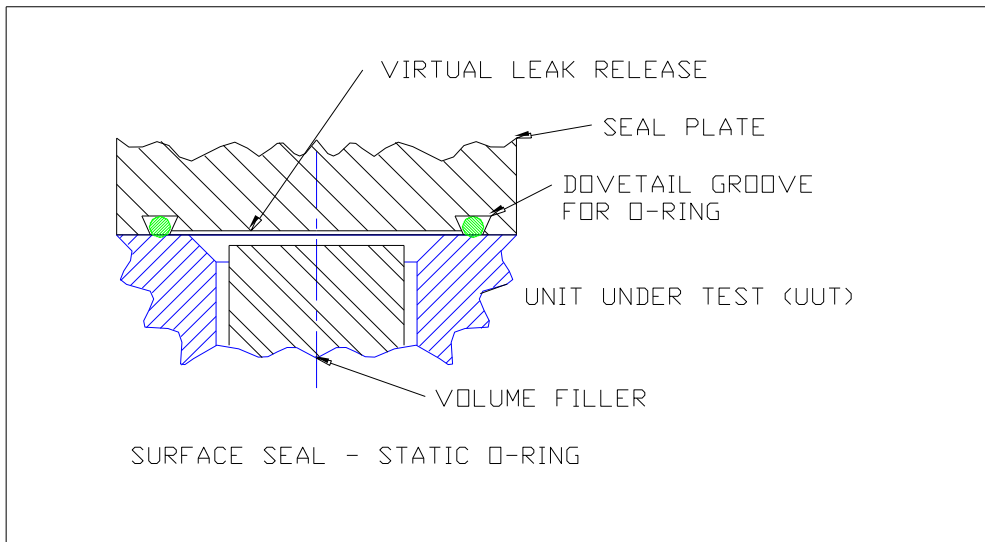

Figure 3.4.1: Surface seal design with static o-ring.

Note: Top plate contacts the part to provide hard stop and prevent movement during test.

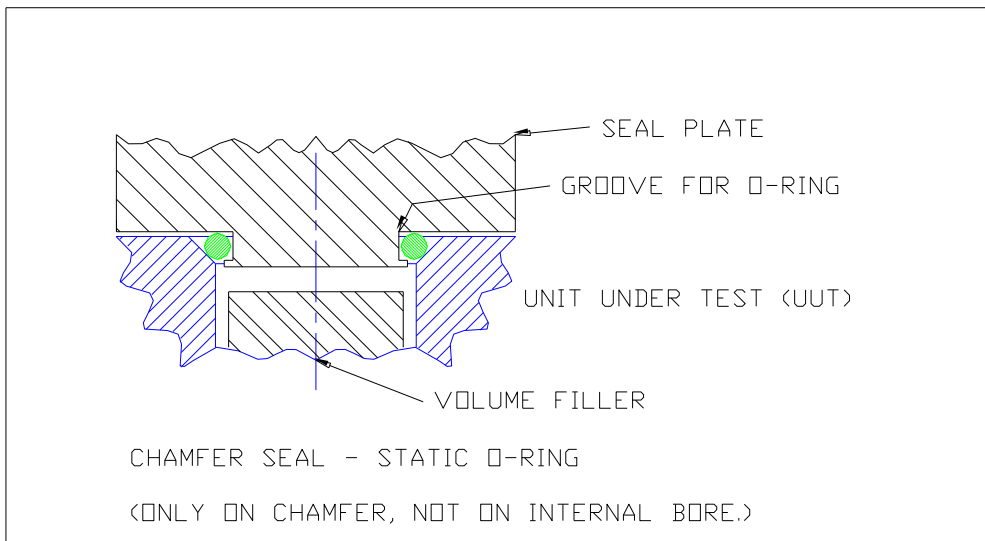

Figure 3.4.2 Chamfer seal design using o-ring.

Seal plate contacts the part, to provide hard stable stop.
(Note: Seal should not seal on the internal bore.)

INTERFACE

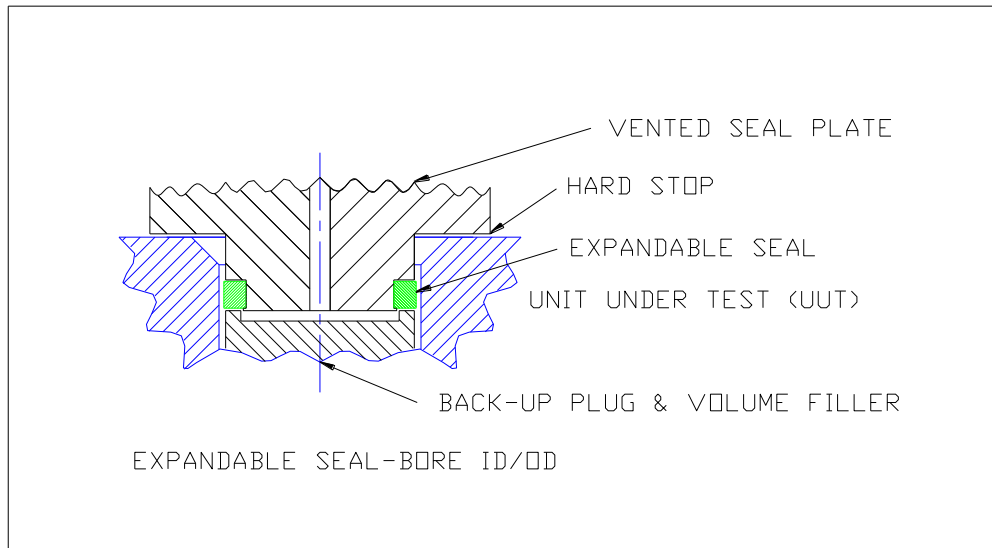

Figure 3.4.3 Expandable seal design

Seal expands as seal plate moves downward. Same concept can also be applied to ODs. Seal plate contacts the part to provide stable hard stop.

3.5 Guideline for setting up Model E2 or Model VE2 leak tester

1. Un-pack the Model E2 or Model VE2 and make sure the unit is in good condition with the proper caps and ferrules.
2. Power Model E2 or Model VE2 and check reading. The temperature and pressure should read close to ambient.
3. Connect expansion tank per schematic.
4. Connect pressure source and pressurize unit to test pressure, allow time to stabilize; make sure all the connections are leak free.
5. Run test with the unit capped with the brass cap provided. The reading should be close to "zero". If hi or low flow is observed, check all upstream and downstream connections for leaks.
6. Run test with the internal calibrated leak open. The reading should be close to the orifice value as indicated on the tag at the back of the Model E2 or Model VE2.
7. Procure multiple non leaking parts
8. Connect PC or Laptop to the Model E2 or Model VE2 serial Port.
9. Open Leak-Tek and go to the set up screen and input the desired pressure setting with +/-10% on the min/max pressure. Input the desired flow unit and Pre-fill, fill stability and test and min/max flow. Make sure the max flow is higher initially and the min flow about -ve 2% of the sensor full scale or above the sensor zero offset (ex. for a 10ccm

INTERFACE

full scale sensor min flow could be -0.2ccm). Deplete pressure must be checked in the setup screen if the pressure needs to be exhausted at the end of the test.

10. Run test with the good parts and then run the good parts with the internal calibrated leak open.
11. Make sure the difference between the good parts and the simulated bad parts is 2 times or more, adjust the timing accordingly.
12. The max flow criteria should be set at 20% below the average of the simulated bad parts.

3.6 Verification Procedure

A periodic verification is recommended during the normal operation of the Model E2 or Model VE2. Run test with a known good part and the internal calibrated leak open. This should fail the test. Run a similar good part without the internal calibrated leak and this should pass the test. If this sequence does not give the desired results, the system and/or parts should be checked or verified, and the procedure repeated until the desired result is obtained.

CAUTION:

A test time should be more than 1 sec and the buffer size 4-30. Consult the Leak-Tek © software manual for information on how to set these variables.

4. IGLS-Model E2 or Model VE2 Operation Sequence

The Model E2 or Model VE2 leak test will run based on the sequence below after the “start” button is pressed on the front panel.

The IGLS/IGFS/IMFS (version 02.00.00 or later) has one dedicated analog output to represent the real-time flow measurement. The other analog output can be used as pressure control or flow control depending on the sensor type.

A typical IGLS Test Sequence is as follows:

1. Energize the clamping valve in order to clamp, or connect a pneumatically driven clamp or an automatic expander seal.
2. After clamping time delay:
 - a. Open the pressure valve
 - b. Open the fill valve to pressurize the UUT (Unit Under Test)
3. After filling valve delay:
 - a. Close the fill valve
4. After stability time expires, start the leak test. (The stability time can be as short as 0.01 seconds for Mass Extraction applications.)
5. If the UUT meets the test criteria within the set test time, the UUT has passed the test.
 - a. If the test is passed, de-energize all valves to deplete the pressure and display the pass message.
6. If the UUT fails the test criteria at any point during the set test time, the failure message will display.
 - a. Continue re-testing if the “deplete pressure” feature is disabled. ($X_5=0$. See Appendix B command list.)
 - b. If the “deplete pressure” feature is enabled, de-energize all valves. ($X_5=1$. See Appendix B command list.)

CAUTION:

A test time should be more than 1 sec and the buffer size 4-30 .
--

1. Passing or failing a test:
 - a. If the UUT meets the test criteria within the set test time, the UUT has passed the test. If the test passes, all valves will be de-energized to deplete the pressure from the UUT and to contain the internal system pressure, the GREEN “Pass” message will be displayed on the LCD.
 - b. If the UUT fails the test criteria at any point during the test time, the UUT has failed the test. If the test fails, the RED “Fail” message will be displayed on the LCD.

Continue re-testing if the "deplete pressure" feature is disabled. ($X_5=0$. See Appendix B command list.) If the "deplete pressure" feature is enabled, de-

OPERATION SEQUENCE

energize all valves. ($X_5=1$. See Appendix B command list) The Model E2 or Model VE2 needs to be stopped manually by pressing the stop button

2. If the “stop” button on LCD display is pressed at any time during the test process, the test will be stopped with all valves back to standby state and the analog output at zero.
3. To switch to the other test type, press the “Type” button on LCD Display or pulse the “remote type select” digital input.

NOTE:

If a PC is attached to the Model E2 or Model VE2 with “Leak-Tek program©” running the Pass/Fail will be displayed in the Leak-Tek program © run screen; however the Pass/Fail decision is made by the Model E2 or Model VE2.

CAUTION:

During normal operation if a part failed due to failure mode “Flow saturation” or “Gross Leak” the isolation tank can get significantly depleted. If this condition happens the tank should be allowed to recover and get back to its original condition and no leak test should be run during this recovery period. Repeat verification procedure.

NOTES:

1. When the UUT has a large volume and a small flow IGLS is used, “back flow” due to pressure fluctuations from the UUT will “mask” leaks. Therefore, set V4 to 0 to “lock” the pressure output if the electronic pressure controller is used (This option is applicable when running with an external pressure controller).
2. For high-speed applications, and especially low flow, the Model E2 or Model VE2 is recommended to monitor the change in flow rates. Initially set fill and stability time to very long values and record changes in flow vs. time. Define the slope for a good and rejected part. Then set the stability time and maximum flow rate to meet this slope. Use the verification orifice for reference of known leak rate.
3. For mass extraction method, the leak criteria (V_2) depends on the size of the UUT leak, the size of the chamber if applicable, and the test time.
4. Typically:
 - a. The larger the UUT leak, the larger the leak criteria will be.
 - b. The smaller the chamber, the larger the leak criteria will be.
 - c. The longer the test time, the larger the leak criteria will be.

5. Graphic LCD Display & Touch Screen

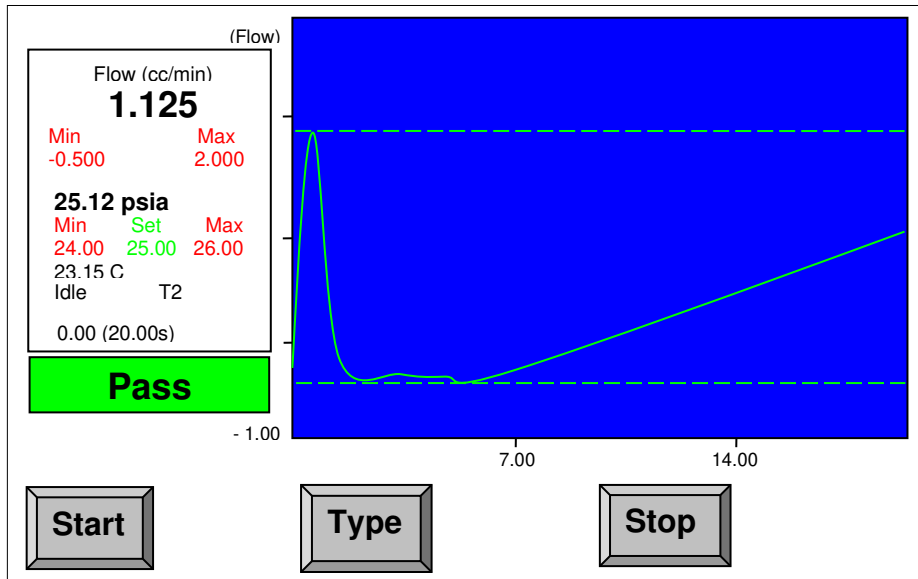

Figure 5.1 - Model “E2” or “VE2” LCD

The Model E and Model VE graphical LCD is shown in Figure 5.1. On the left, the current pressure, temperature and flow readings are displayed in real time as well as the pressure and flow settings. The pressure, temperature, and/or flow, in the user selected engineering units by programming U₃, U₄, and U₅. (See Appendix B for details.)

On the right, a blue background graph displays the flow measurement signature for the entire leak test. The two dotted lines represent the upper and lower limits of the leak test flow tolerance. The solid line is the flow measurement.

At the bottom of the screen, there are three toggle buttons available. The visibility of the buttons can be individually configured. If they are visible, then:

Start: Start a leak test if it is idle

Stop: Stop an ongoing leak test

Type: Switch from one Test Type to the other, increment by one (1) or back to Test Type 1 if it reaches the maximum number of the test types.

On the right side of the status message, it will display T1 if it is in test Type 1 Mode, T2 if it is in test Type 2 Mode, T3 if in Test Type 3 and T4 if in Test Type 4. If the sensor is only use two test type and the **Type** button is hidden, there is no message like “T1” in the Test Type 1.

The verification switch opens or closes the calibrated leak valve to initiate flow through the calibrated leak.

COMMUNICATION PROTOCOL

The following table shows the various messages possible on the LCD.

Message	Description
Idle	Displays the pressure and flow reading in flow measurement, together with engineering unit in normal condition.
OpenFillPres	Displays the pressure and flow reading with the step status in the process of the test. The IGLS will open the pressure valve and filling valve.
Filling	Displays the pressure and flow reading with the step status in the process of the test. The IGLS is filling gas.
Stab Delay	Displays the pressure and flow reading with the step status in the process of the test. The IGLS is stabilizing the flow for testing.
Testing	Displays the pressure and flow reading with the step status in the process of the test. The IGLS is in test step.
Pass	Displays the pressure and flow reading with pass message after the test passed.
Stop	Displays the pressure and flow reading with stop message, if the test is intentionally stopped manually.
Fail	Displays the pressure and flow reading with failure message if the test fails. The reason for failure is shown on the LCD.
GrossLeak	During test time, pressure is under Pressure Min (K3) setting in pressure testing
GrossLeakV	During test time, pressure exceeds Pressure Max (K2) setting in vacuum testing
No-Pres	Pressure Switch not turned on in time (Version 2.0.0 or later)
OverPres	During test time, pressure exceeds Pressure Max (K2) setting in pressure testing.
UnderPres	During test time, pressure is under Pressure Min setting in vacuum testing
PresSat	Pressure exceeds its full range. Deplete pressure immediately!
FineLeak	During Test, flow is larger than maximum allowed flow (V2), or the accumulated flow during the test period is larger than the allowed leak (V2)
Low Flow	During test, flow is lower than minimum allowed flow (V1).
FlowSat	Flow exceeds maximum sensor flow range.
TempSat	Temperature exceeds maximum limit.
Blockage	Pressure Switch not turned off in deplete time
HiFlow_RM	Relative Measurement –Baseline Flow larger than V6
LoFlow_RM	Relative Measurement –Baseline Flow smaller than V5
LargeLeak	In large leak step, the measured flow is larger than V7
BackFlow	The measured flow in the test step is less than A3
PresRng-Hi	External Pressure higher than set limit (KA)
PresRng-Lo	External Pressure Lower than set limit (K9)
ExtGrossLeak	External Gross Leak Failure (External Pressure Sensor reading

COMMUNICATION PROTOCOL

	Lower than K3)in pressure testing.
ExtOverPres	External Over Pressure Failure (External Pressure sensor reading larger than K2) in pressure testing.
ExtUnderPres	External Under Pressure Failure (External Pressure sensor reading Lower than K3) in vacuum testing.
ExtGrossLeakV	External Gross Leak Vacuum Failure (External Pressure sensor reading larger than K2) in vacuum testing.

If the valve control sequence is customized, some of the LCD messages displayed might be worded slightly different from the diagram above. However, the messages can be interpreted in a similar fashion.

NOTE:

Starting from version 02.02.01, once the UUT failure is found, it will not be overwritten by the next failure if multiple failures occurred in the same UUT. For example, if both fine leak and blockage failures were found in the test. It will report fine leak failure because it was found first.

The detailed explanations of the graphical LCD are as follows:

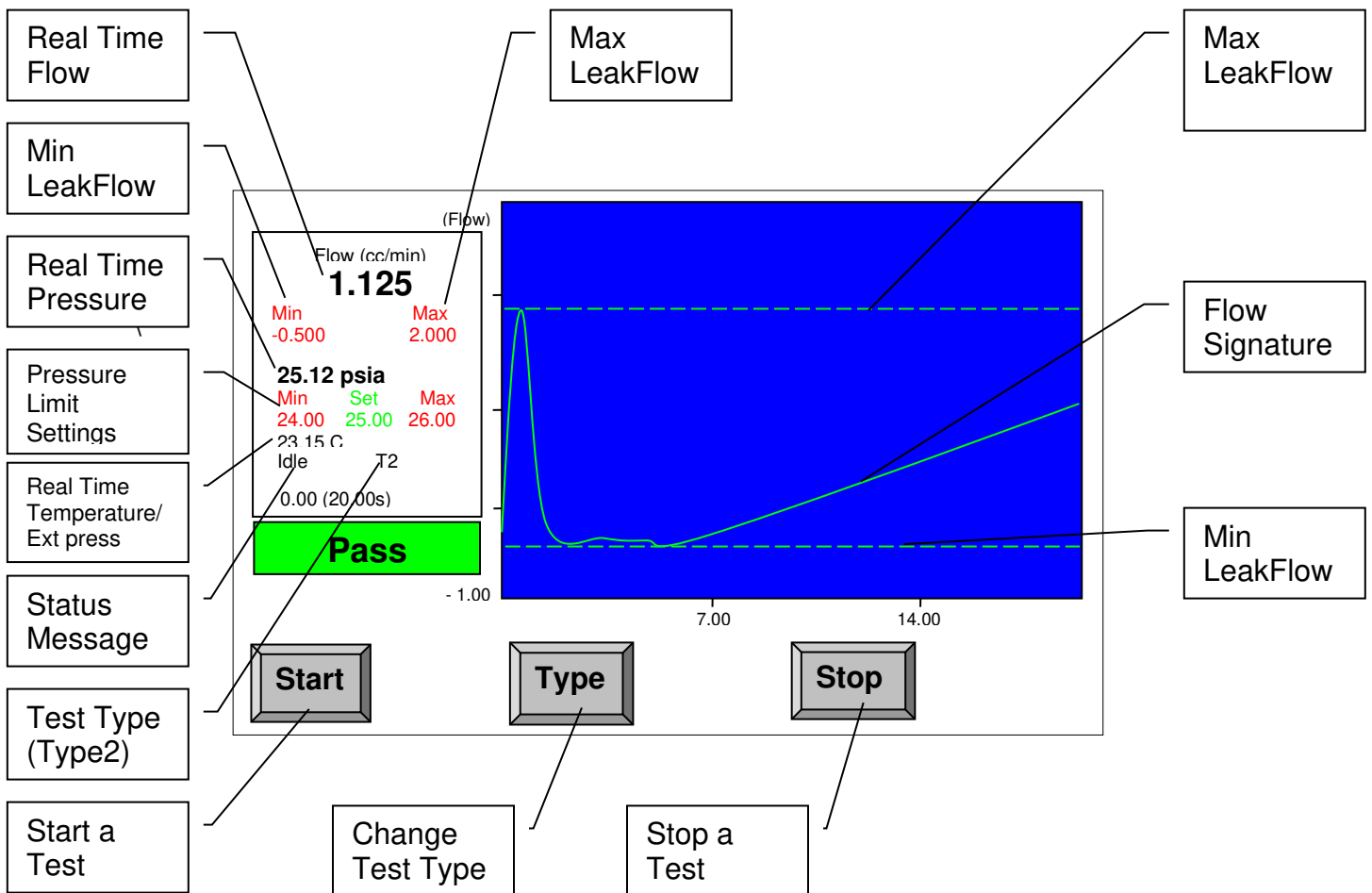

Figure 5.2 - Model "E2" or "VE2" LCD Elements

The Real Time Pressure and Pressure Settings can be used to display the internal pressure or external pressure sensor(if used in the system) reading. The user can configure it through the Leak-Tek serial software provided by Pfeiffer-Vacuum.

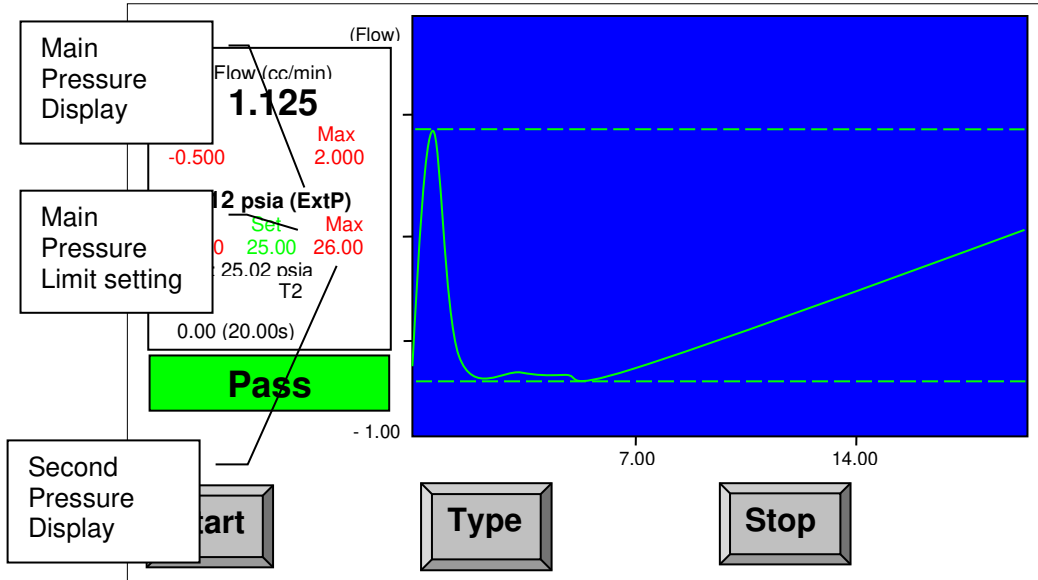

Figure 5.3 - LCD Display with External Pressure sensor replacing Internal Pressure sensor display.

After firmware 2.3.11, the configuration of External and Internal pressure sensor reading display is available from Leak-Tek(version 6.06 or later). The user can choose the either internal or external pressure reading on the main pressure display and the other on the second pressure display, as Figure 5.3 shows. When the external pressure is configured to be displayed in Main Pressure Display, the “ExtP” will follow the pressure unit to imply the pressure reading is external pressure. In the second pressure display, the capital “IntP” or “ExtP” is used to imply internal or external pressure reading is displayed. The second pressure display can also be hidden if user prefers or no external pressure sensor is used. The Main pressure limit setting is used to display the Min and Max limit of the pressure set as main pressure display. Please refers the Leak-Tek manual, section 9.2.3 (version 6.06 or later) to know how to configure the pressure display.

Note: The internal pressure sensor is normally an absolute pressure sensor use for measurements and units conversions (from volume flow to mass flow). The external pressure sensor can be a gage or an absolute pressure sensor. At low test pressure (under +/- 3 psi) the external pressure sensor, if a gage sensor, will not change due to barometric pressure changes. Both sensors must have same pressure measurement units.

6. Communication Protocol

NOTE:

All commands and responses should be terminated by <lf><cr>

6.1 Conventional Commands for Sensor Parameters

Read Command Format:

“!0” + ADDRESS + ”R” + COMMAND

Response Format:

“\$0”+ ADDRESS +”R” + COMMAND; DATA

Save Command Format:

“!0” + ADDRESS + ”S” + COMMAND; DATA

Response Format:

“\$0”+ ADDRESS + ”S” + COMMAND; DATA

where

ADDRESS is valid from 0 to 9. (The first sensor will be respond to 0)

DATA is the number to be saved or read.

COMMAND, see Appendix B.

For example, to change G1 to the 287(Air) in IGLS addressed as 2, the command string will be as follows

```
!02SG1;287.0<lf><cr>
```

Note:

For commands such as U2, U3, U4, U5, the returned DATA are in Hex format of “oxFFFFFFF” in version 2.0.0 or later, however, the data in the command will be treated as a decimal value unless there is a prefix “0x”. For example, either of the following command will change IGLS addressed as 1 to flow unit mg/min.

```
!01SU5;91 <lf><cr>
```

```
!01SU5;0x51 <lf><cr>
```

6.2 DAQ Commands

DAQ string response is in the form of \$01SQ1;Data1;Data2;Data3;StepNo

Where

Data1: temperature reading

Data2: pressure reading

Data3: flow reading

Step No: The step no. will be interpreted as a Hex value, especially if the sensor is configured to run more than 9 steps. For more details, see Section 6.3.

COMMUNICATION PROTOCOL

For Firmware 2.3.4 and greater, the DAQ string response is in the form of !01SQ5; Data1;Data2;Data3;Data4;Data5;StepNo

Where

Data1: temperature reading

Data2: pressure reading

Data3: flow reading

Data4: external pressure reading

Data5: adaptive test flow reading

StepNo: The step no will be interpreted as Hex value, especially if the sensor is configured to run more than 9 steps. For detail, see Section 6.3.

SQ1;1	<p>Command: !01SQ1;1 Response: \$01SQ1;Data1;Data2;Data3;StepNo Engineering Value and Step where if (X6<>0) then Data1 refers to temperature in Degree C Data2 refers to pressure in kPa Data3 refers to flow in cc/min or $\mu\text{g}/\text{min}$ Otherwise Data1 refers to temperature in the selected temperature unit. Data2 refers to pressure in the selected pressure unit. Data3 refers to flow in the selected flow unit.</p>
SQ1;2	<p>Command: !01SQ1;2 Response: \$01SQ2;Data1;Data2;Data3;StepNo Average Count Value and Step Data1 refers to temperature in digital count. Data2 refers to pressure in digital count. Data3 refers to flow in digital count.</p>
SQ1;3	<p>Command: !01SQ1;3 Response: \$01SQ3;Data1;Data2;Data3;StepNo Engineering Base Unit Value and Step Data1 refers to temperature in Degree C Data2 refers to pressure in kPa. Data3 refers to flow in cc/ or $\mu\text{g}/\text{min}$</p>
SQ1;4	<p>Command: !01SQ1;4 Response: \$01SQ4;Data1;Data2;Data3;StepNo Engineering Display Unit Value and Step Data1 refers to temperature in the selected temperature unit. Data2 refers to pressure in the selected pressure unit. Data3 refers to flow in the selected flow unit.</p>
SQ1;5	<p>Command: !01SQ1;5</p>

COMMUNICATION PROTOCOL

	<p>Response: \$01SQ5;Data1;Data2;Data3;Data4;Data5;StepNo</p> <p>Data1 refers to temperature in Degree C</p> <p>Data2 refers to pressure in kPa</p> <p>Data3 refers to flow in cc/min or $\mu\text{g}/\text{min}$</p> <p>Data4 refers to external pressure (4th analog input) in kPa</p> <p>Data5 refers to Adaptive flow or steady state flow in cc/min or $\mu\text{g}/\text{min}$</p>
SQ1;6	<p>Command: !01SQ1;6</p> <p>Response: \$01SQ6;Data1;Data2;Data3;Data4;Data5;StepNo</p> <p>Data1 refers to temperature in digital count.</p> <p>Data2 refers to pressure in digital count.</p> <p>Data3 refers to flow in digital count.</p> <p>Date4 refers to external pressure (4th analog input) in digital count</p>
SQ1;7	<p>Command: !01SQ1;7</p> <p>Response: \$01SQ7;Data1;Data2;Data3;Data4;Data5;StepNo</p> <p>Engineering Base Unit Value and Step</p> <p>Data1 refers to temperature in Degree C.</p> <p>Data2 refers to pressure in kPa.</p> <p>Data3 refers to flow in cc/min or $\mu\text{g}/\text{min}$.</p> <p>Date4 refers to external pressure (4th analog input) in kPa</p> <p>Data5 refers to adaptive flow in cc/min or $\mu\text{g}/\text{min}$</p>
SQ1;8	<p>Command: !01SQ1;8</p> <p>Response: \$01SQ8;Data1;Data2;Data3;Data4;Data5;StepNo</p> <p>Engineering Display Unit Value and Step</p> <p>Data1 refers to temperature in selected temperature unit</p> <p>Data2 refers to pressure in selected pressure unit</p> <p>Data3 refers to flow in selected flow unit</p> <p>Date4 refers to external pressure (4th analog input) in selected pressure unit</p> <p>Data5 refers to adaptive flow in selected flow unit</p>
SQ1;9	<p>Command: !01SQ1;9</p> <p>Response: \$01SQ9;Data1;Data2;Data3;StepNo;TimeStamp</p> <p>Engineering Value and Step</p> <p>where</p> <p>if (X6<>0) then</p> <p>Data1 refers to temperature in Degree C</p> <p>Data2 refers to pressure in kPa</p> <p>Data3 refers to flow in cc/min or $\mu\text{g}/\text{min}$</p> <p>Otherwise</p> <p>Data1 refers to temperature in the selected temperature unit.</p> <p>Data2 refers to pressure in the selected pressure unit.</p> <p>Data3 refers to flow in the selected flow unit.</p>
SQ1;A	<p>Command: !01SQ1;A</p> <p>Response:</p> <p>\$01SQA;Data1;Data2;Data3;Data4;Data5;StepNo;TimeStamp</p>

COMMUNICATION PROTOCOL

	<p>Data1 refers to temperature in Degree C Data2 refers to pressure in kPa Data3 refers to flow in cc/min or $\mu\text{g}/\text{min}$ Data4 refers to external pressure (4th analog input) in kPa Data5 refers to Adaptive flow in cc/min or $\mu\text{g}/\text{min}$</p>
SQ1;B	<p>Command: !01SQ1;B Response: \$01SQB;Data1;Data2;Data3;Data4;Data5;StepNo;TimeStamp Engineering Display Unit Value and Step Data1 refers to temperature in selected temperature unit Data2 refers to pressure in selected pressure unit Data3 refers to flow in selected flow unit Date4 refers to external pressure (4th analog input) in selected pressure unit Data5 refers to adaptive flow in selected flow unit</p>
SQ2;1	<p>Command: !01SQ2;1 Response: \$01SQ2;1 Auto Zero to update C1</p>
SQ2;2	<p>Command: !01SQ2;2 Response: \$01SQ2;2 Auto Zero to update C5</p>
SQ2;3	<p>Command: !01SQ2;3 Response: \$01SQ2;3 Auto Zero to update C1 and C5</p>
SQ3; 0-3	<p>Command: !01SQ3;0 to Set the Parameter to Type 1 Command: !01SQ3;1 to Set the Parameter to Type 2 Command: !01SQ3;2 to Set the Parameter to Type 3 Command: !01SQ3;3 to Set the Parameter to Type 4 Response: Don't care the response</p> <p>Note: After the command is sent, all following commands related to T, V, and K groups are corresponding to that test type regardless what the current test type is.</p>
RQ3	<p>Command: !01RQ3 Response: \$01RQ3;0: Currently in Test Type 1 Response: \$01RQ3;1: Currently in Test Type 2 Response: \$01RQ3;2: Currently in Test Type 3 Response: \$01RQ3;3: Currently in Test Type 4</p> <p>Note: This command only returns with the which test type currently active, which is decided by the test type toggle switch digital input to the sensor, independent of SQ3 command result.</p>

NOTE:

For all SQ1 commands, the sensor will respond with two strings with the first string similar to \$00SQ1;1, DAQ string as the second one if U6<>0. Otherwise, it will respond with the DAQ string only.

If the sensor is configured as mass extraction mode, Data1 carries the accumulated mass or volume instead of temperature during the test step.

SQ1;1 Command ONLY

When the mass extraction method is used, Data1 will refer to the temperature in °C or in the selected temperature unit in all sensor steps except in the test step. In the test step, Data1 represents the real-time accumulated leak in the selected mass or volume unit.

For example, mg if mg/min is selected as flow unit.
Liter if liter/hr is selected as flow unit.

If the sensor is configured as an adaptive leak tester, Data1 carries the predicted flow instead of temperature during the test step.

SQ1;1 Command ONLY

When the sensor is configured as adaptive leak tester, Data1 will refer to the temperature in degree C or in the selected temperature unit in all sensor steps except in the test step. In the test step, Data1 represents the real-time calculated leak in the selected mass or volume unit.

Before the firmware 2.3.14, the length limit of the response message is **55** characters. For Firmware 2.3.14 and greater, the limit of the message length is **75** characters

6.3 Step Number

Typical Step Number Table (Hex System)

Step	Built-in Sequence	Customized Sequence/Description
0, 100	Standby	Standby
1	Open Clamping Valve	Customized
2	Open Pressure and Fill Valve	Customized
3	Filling	Customized
4	Stability	Customized
5	Test	Customized
6,7	Close all valves	Customized
8	Stop	Customized
9	Customized	Customized
A		Customized
B		Customized
C		Customized
D		Customized
E		Customized
F		Stop*
16	Pass	Pass
17	Pass-RM	Pass – Relative Measurement
18	Pass-RF	Pass – Reference Flow Measurement (The reference flow test must be enabled and activated in the current test type. Please refer the Leak-Tek manual (version 6.06 or later) section 6.3.3 and 5.3.3.1).
21	PresSat	Pressure Sensor Saturated Failure
22	FlowSat	Flow Sensor Saturated Failure
23	TempSat	Temperature Sensor Saturated Failure
24	GrossLeak	Gross Leak Failure (Pressure Lower than K3)in pressure testing
25	FineLeak	Fine Leak Failure (Flow larger than V2)
26	Low Flow	Low Flow Failure (Flow Lower than V1)
27	OverPres	Over Pressure Failure (Pressure larger than K2) in pressure testing
28	BackFlow	Backflow Failure (Flow sensor smaller than A3)
29	Blockage	Blockage Failure –Pressure Switch not turn off in deplete time (T6)
2A	No-Pres	No Pressure Failure (Pressure Switch not turned on in time)
2B	HiFlow_RM	Relative Measurement Baseline Flow Too High

COMMUNICATION PROTOCOL

2C	LoFlow_RM	Relative Measurement Baseline Flow Too Low
2D	LargeLeak	Large Leak Check Failure (Flow larger than V7 at Large Leak check Step)
2E	UnderPres	Under Pressure Failure (Pressure Lower than K3) in vacuum testing
2F	GrossLeakV	Gross Leak Vacuum Failure (Pressure larger than K2) in vacuum testing
30	PresRng-Hi	External Pressure higher than set limit (KA)
31	PresRng-Lo	External Pressure Lower than set limit (K9)
32	ExtGrossLeak	External Gross Leak Failure (External Pressure Sensor reading Lower than K3)in pressure testing.
33	ExtOverPres	External Over Pressure Failure (External Pressure sensor reading larger than K2) in pressure testing.
34	ExtUnderPres	External Under Pressure Failure (External Pressure sensor reading Lower than K3) in vacuum testing.
35	ExtGrossLeakV	External Gross Leak Vacuum Failure (External Pressure sensor reading larger than K2) in vacuum testing.

Figure 6.1 - Step Number Interpretation

The Step number in DAQ response string shall be interpreted as a Hex Value although there is no hex prefix such as "0x". Any step numbers between 1 to E could be valid step numbers depending on the customized valve sequence. For example, the sensor is configured to have 12 steps in the test. The customized step number shall be C(12) steps. D(13) will be reported in the DAQ response string of the stop step if the user pushes the stop button during the test. Step numbers between 10 and 100 shall be interpreted exactly the same among all sensor versions and all different configurations.

7. Maintenance and Troubleshooting

7.1 Periodic Maintenance and Calibration

WARNING:

Only qualified and trained professional should operate and maintain the Leak Test Instrument, Model E2 or Model VE2.

WARNING:

The internal calibrated leak is an integral part of the Model E2 or Model VE2. Under no circumstances should it be opened or tampered with.

WARNING:

The Model E2 or Model VE2 contains pressure. Make sure to deplete internal pressure before doing any maintenance work that requires opening any internal components.

WARNING:

The Model E2 or Model VE2 contains AC lines, power supply and valves. Disconnect the power cord from the power outlet before removing the Model E2 or Model VE2 cover and during any electrical work.

WARNING:

The Model E2 or Model VE2 should only be serviced by trained and authorized personnel. If for any reason the Model E2 or Model VE2 needs to be opened for troubleshooting or service, call Pfeiffer-Vacuum first for authorization.

7.1.1 Filter

The IGLS Model E2 or Model VE2 is provided with an in-line filter. The filter is at the inlet of the IGLS. Periodically clean or replace the filter, as necessary. Consult Pfeiffer-Vacuum.

7.1.2 Periodic Calibration

The IGLS in Model E2 or Model VE2 is a measuring device. Periodic calibration, typically annually, by authorized personnel and standards is required. Refer to the Leak-Tek © or GAS-CAL© manuals for the instrument calibration procedures. Consult Pfeiffer-Vacuum.

7.1.3 System performance Verification

The IGLS Model E2 or Model VE2 can be supplied with an internal calibrated leak (optional) or equivalent channel standard (optional) that are calibrated at certain pressure and flow. A valve isolates the orifice. This valve can be turned on and off by the calibration switch provided in the front panel. The verification orifice shall not be used for instrument calibration, but system performance verification and diagnosis of a component failure (such as valve or a system

MAINTENANCE AND TROUBLESHOOTING

leak). Follow the following procedure to verify the Model E2 or Model VE2 performance:

- Set the system pressure and allow it to stabilize.
- Open the calibration valve and allow the flow to stabilize.
- Record the IGLS readings and compare them to calibrated leak flow calibration at that pressure.

NOTE:

When comparing to equivalent channel standard calibration data, compensation must be performed for different gases, pressure and temperature.

- With a new, proven unit and system, (FIRST TIME AFTER INSTALLATION) set up one test and make a sample test (same test parameters). Establish the system verification flow tolerance. Recommended tolerance is +/- 3 times the standard deviation of the initial sample.
- Periodic readings should be taken at the same test setup and compared to the flow verification tolerance. If readings (at same pressure range) are higher, after a few tests, look for a leak downstream from the IGLS. If the readings are too low, look for a leaking fill valve, upstream leak or clogged inlet filter or lines. In each case, the cause of the problem (readings out of the verification tolerance) must be resolved prior to continuing a test.

7.2 Troubleshooting

The following table summarizes some common problems that may occur, and repair recommendations.

No.	Description	Possible Cause	Repair Action
1	LCD doesn't light	Power supply 5 VDC not available Bad LCD or internal component	Check power supply Check D connector Measure 5 VDC and common Consult Pfeiffer-Vacuum
2	LCD Only Display Partial Screen	The LCD momentarily lost power	Turn off and turn on the power supply. Click the two buttons Deactivate and Activate in the LeakTek Run Screen.
3	No communication with PC and data saving	Communication problem	Check 9-pin RS232 cable between Model "E" and PC Check PC COM port settings Check Model "E" address Power down the unit, wait 2 minutes before power up
4	Test will not start	Damaged wiring Bad control panel component Bad remote I/O connection.	Check for damage to internal wiring Consult Pfeiffer-Vacuum Remove remote I/O cable and start test from the button on the front panel
5	Valves not working	Valves are not enabled Damaged wiring Bad valves Bad control panel components Bad remote I/O connection.	Checked valve matrix and make sure they are enabled. Check for damage to internal wiring Check valves; Consult Pfeiffer-Vacuum for replacement parts Remove remote I/O cable and start test from the button on the front panel Consult Pfeiffer-Vacuum

MAINTENANCE AND TROUBLESHOOTING

No.	Description	Possible Cause	Repair Action
6	Pressure controller does not get to zero, no control	No analog voltage output 12 VDC not available Defective pressure control	Check analog output voltage on rear panel connector Check for damage to internal wiring Power down the unit, wait 2 minutes before power up; Analog voltage output should be 0. If not, consult Pfeiffer-Vacuum. Check 12 VDC supply Check for defective pressure/flow controller CHECK P GROUP VARIABLES, SET TO 0 (DISABLE PID) AS REQUIRED.
7	Pressure Sensor readings are incorrect	Measurement units are not set properly Pressure sensor has large offset-sensor was over pressurized. Pressure sensor calibration coefficients corrupted Loose connection No power supply	Verify measurement units using Leak-Tek program. Check pressure sensor calibration and verify proper calibration coefficients. Check for 12 VDC power supply In case of large reading offset, typically pressure sensor was over-pressurized. Contact Pfeiffer-Vacuum.
8	IGLS shift of flow	Wrong units of meas. Temperature variation IGLS tilted	Check set up and units Go to configuration screen and check A/D counts of Flow sensor. Tilt sensor to see if "zero" returns. See Auto zero procedure Press must be stable in standby mode. Consult Pfeiffer-Vacuum.
9	IGLS flow reading High all the time, and in standby mode.	Leakage downstream to the IGLS Fill valve not opening Pressure valve leakage IGLS zero shift or unit has moved	Isolate IGLS/Model E2 or Model VE2 by plugging the UUT outlet, check downstream fittings and tubing to the IGLS. Go through initial setup procedure Check/replace press, calibration and exhaust valve. Check / replace fill valve If high readings persist, plug the IGLS outlet, check A/D counts

MAINTENANCE AND TROUBLESHOOTING

			and compare to original calibration. Auto zero the sensor if A/D counts are below 200.
--	--	--	--

No.	Description	Possible Cause	Repair Action
10	IGLS flow reading too low or very negative (A/D counts is "0").	Leakage through the fill line Leaking fill valve External leakage through the expansion tank or isolation valve. Unstable supply pressure-pressure drops down. Unit clogged	Check/replace inlet filter Check supply pressure Isolate and check fill/by-pass lines Check leakage through fill valve. Check for expansion tank or isolation valve leak. Verify calibration coefficients Check for leaks at the IGLS outlet plugs and fittings Consult Pfeiffer-Vacuum for internal cleaning instructions. DO NOT AUTO ZERO the flow sensor if flow or any A/D counts are "0"
11	IGLS Flow, pressure and temperature readings do not make sense	Calibration scrambled Power supply damaged	Verify power supply outputs Verify calibration data with original cal. sheet. Check/increase buffer size (Less than 30) Check that unit reacts normally (pressure flow readings varies with flow) Recalibrate the unit
12	Cannot pass verification test with the calibrated leak	Upstream leak to leak tester Bad Pressure regulator Equivalent Channel or calibrated leak are plugged. Leaking fill valve Isolation valve is not closing during stability and test time IGLS measurement is incorrect.	Check test criteria and flow reading Check flow calibration coefficients. Check for upstream and expansion tank connections. Replace pressure regulator. Plug the leak tester output and repeat the test. Externally connect another Equivalent Channel (Calibrated Leak) to verify that internal calibrated leak is not plugged. If plugged- replace internal Equivalent Channel. See line (4) Consult Pfeiffer-

MAINTENANCE AND TROUBLESHOOTING

			Vacuum to replace defective valves. See lines 8,9,10.
--	--	--	--

No.	Description	Possible Cause	Repair Action
13	Test Starts/stops by itself when connected to a remote PLC or PC control system	Current leakage into the opto-isolated inputs of the IGLS	Verify that start and stop signals are through dry contact relay. Install one if missing!
14	IGLS Pressure or Flow readings unstable	Upstream pressure fluctuation cannot be damped enough by the expansion tank Incorrect remote I/O connections. Unstable Power Supply Bad connection	Check Model E2 or Model VE2 or IGLS connections. Disconnect I/O connector, to isolate for test machine possible common-ground problems. Check power supply Check internal IGLS connection Check upstream pressure, increase expansion tank size and add an isolation valve if required. Check precision regulator.
15	LCD screen is distorted	Power Spike or rough handling of the instrument may cause the LCD	Touch the right hand side of the LCD screen to refresh the screen.

Figure 7.2.1 - Troubleshooting

Appendix A - Calculation Algorithm

1. Density Calculation

$$D = \frac{P+Q*V_3}{G_1*(T+273.15)}$$

where

D Density of the gas in mg/cc

G₁ Constant of the gas (For example, Air = 287)

P Pressure Measurement in Pa

T Temperature of the gas in degree C

Q Flow Measurement in cc/min.

V₃ Flow compensated Pressure Coefficient (See Appendix B)

2. Volumetric Flow Calculation

If Two Set of Calibration is disabled, then One Set of Calibration is used.

Base Unit Flow is calculated as follows:

$$F = C_1 + C_2 * x + C_3 * x^2 + C_4 * x^3$$

Where

x: The average count of flow sensor

F: Base Unit flow in cc/min or µg/min

Two Set of Calibration

All C Group (C1-CA) are Enabled

Count	α	Range
<65535*(C ₉ -C _A)/100	1	Low Range
>65535*(C ₉ +C _A)/100	0	Normal Range
65535*(C ₉ -C _A)/100< <65535*(C ₉ +C _A)/100	α=(65535*(C ₉ +C _A)/100-x)/(65535*2* C _A /100)	Transient Area Between Low and Normal range

Base Unit Flow is calculated as follows:

$$F = (1 - \alpha) * (C_1 + C_2 * x + C_3 * x^2 + C_4 * x^3) + \alpha * (C_5 + C_6 * x + C_7 * x^2 + C_8 * x^3)$$

Where

x: The average count of flow sensor

F: Base Unit flow in cc/min or µg/min

APPENDIX A CALCULATION ALGORITHM

If any of H3, H4, B3, H4 is non-zero, then

$$F_{comp} = F * [(1 + H_4 * (P - H_5) + H_3 * (P - H_5)^2) * [(1 + B_4 * (T - B_5) + B_3 * (T - B_5)^2)]$$

Where:

F_{comp}: Compensated flow

P: Pressure sensor reading

T: Temperature Sensor Reading

Note:

If gas compensation is enabled, then a multiplier needs to be there before the base unit flow is obtained. See the IGLS manual for details.

3. Mass Flow

The mass flow calculation is based on the following formula:

$$dM / dt = Q * \rho$$

where

dM/dt is the mass flow in mg/cc

Q is the volumetric flow in cc/min.

ρ is the density in mg/cc.

3.a Mass Extracted:

$$M = \int_{t_0}^{t_{test}} \frac{dM}{dt} \cdot dt$$

Where:

dM/dt is the mass flow in mg/cc

t₀: The starting time of the test step.

T_{test}: The ending time of the test step.

4. Temperature Calculation

$$T = B_2 + B_1x$$

Where:

x is the count reading from the temperature sensor.

T is temperature in Degrees C.

B₁, B₂ is Temperature Coefficients. (See Appendix B)

5. Pressure Calculation

$$P = H_2 + H_1x$$

Where:

x is the count reading from the pressure sensor.

P is pressure in kPa.

H₁, H₂ is Pressure Coefficients. (See Appendix B)

6. PID Pressure control Calculation (when this function is set and used)

$$u(t) = P1 * e(t) + P2 * \int_{t0}^t e(\tau) \bullet d\tau + P3 * \frac{de(t)}{dt}$$

Where:

P1, P2, P3 are the PID coefficients (See Appendix B).

e(t) is the error between the setting and reading.

APPENDIX B - Command List

Notes:

1. All calibration coefficients are in the unit of °C, flow base unit or kPa if applicable.
2. Density is in the unit of mg/cc.
3. Time is in the unit of 10 ms.
4. All configuration coefficients are in the selected flow unit or kPa if applicable, except for item 5.
5. If X6 is set to 0,
 RS232 data acquisition response is in the selected unit.
 If X6 is set to other than 0,
 RS232 data acquisition response is in the °C, base flow unit or kPa.

B.1 A Group

Command	Type	Note
A1	float	Analog Output Full scale corresponding flow in selected flow unit.
A2	float	D/A calibration, Count/kPa
A3	float	BackFlow if count reading in DP is less than A3
A4	float	Barometric condition of the pressure in kPa
A5	float	Min Pressure for Volume Flow sensor or Max Pressure For Mass Flow Sensor

B.2 B Group

Command	Type	Note
B1	float	Temperature Calibration Slope(C/Count)
B2	float	Temperature Calibration Offset(C)
B3	float	Temperature Compensation Flow Coef (2nd order)
B4	float	Temperature Compensation Flow Coef (Linear)
B5	float	Calibrated Temperature in Deg. C

B.3 C-Group

Command	Type	Note
C1	float	Offset Flow Coef(cc/min or µg/min)
C2	float	First-order Flow Coef(cc/min/count or µg/min/count)
C3	float	Second-order Flow Coef(cc/min/count ² or µg/min/count ²)
C4	float	Third-order Flow Coef(cc/min/count ³ count ² or µg/min/count ²)
C5	float	Lo Offset Flow Coef(cc/min or µg/min)

APPENDIX B COMMAND LIST

C6	float	Lo First-order Flow Coef(cc/min/count or $\mu\text{g}/\text{min}/\text{count}$)
C7	float	Lo Second-order Flow Coef(cc/min/count ² or $\mu\text{g}/\text{min}/\text{count}^2$)
C8	float	Lo Third-order Flow Coef(cc/min/count ³ or $\mu\text{g}/\text{min}/\text{count}^3$)
C9	float	Percent Divider % (such as 10)
CA	float	Smooth % (such as 1)
CB	float	Calibrated Gas Constant
CC	float	Calibrated Gas Viscosity

B.4 D Group

For Adaptive Flow test:

Command	Type	Note
D1	float	Buffer Time in % of the test period
D2	float	Safety Multiplier = 2 to 6
D3	float	Test Start Leak Window Max in multiplier of V2 (1.2)
D4	float	Test Start Leak Window Min in multiplier of V2 (0.8)
D5	float	Alpha (Curve) (0-1)

B.5 G Group

Command	Type	Note
G1	float	Universal Constant of the Gas (287 for air): necessary if density is used in calculation.
G2	float	Viscosity at 0 °C
G3	float	Viscosity change per °C.
G4	float	Density of the gas at standard barometric condition in mg/cc, used for standard flow unit such as SCCM etc
G5	Float	Sensor Alpha (kPa/(cc/min)). $G5=(DP \text{ range})/(\text{Sensor full scale}) * 0.24884$

B.6 H Group

Command	Type	Note
H1	float	Pressure Calibration Slope(kPa/count)
H2	float	Pressure Calibration Offset(kPa)
H3	float	Pressure Compensation Flow Coef (2nd order)
H4	float	Pressure Compensation Flow Coef (Linear)
H5	float	Calibrated Pressure in kPa
H6	float	Pressure Calibration Slope (kPa/Count)
H7	float	Pressure Calibration Offset (kpa)

APPENDIX B COMMAND LIST

B.7 K Group

Command	Type	Note
K1	float	Pressure Setting for Leak Test mode (kPa)
K2	float	Pressure Upper Limit(kPa)
K3	float	Pressure Lower Limit(kPa)
K5	float	Pressure Setting for Leak Test mode (kPa) for large leak check with dual pressure settings
K6	float	Pressure Upper Limit(kPa) for large leak check with dual pressure settings
K7	float	Pressure Lower Limit(kPa) for large leak check with dual pressure settings
K9	float	Pressure Lower Limit (kPa) for external pressure switch
KA	float	Pressure Higher Limit (kPa) for external pressure switch

B.8 L Group

Command	Type	Phase Label
L1...LE	String	Up to 15 characters per Label

B.9 M Group

Command	Type	Phase Valve Configuration
M1	long	This is not saved in the memory. M1;1 to Calibrate the LCD M1;2 to Activate the LCD M1;3 to Deactivate the LCD M1;6 to change the test typeM1;8 to start test M1;9 to stop test
M2	long	Pass Sound Period (x 10ms), Set 0 to disable
M3	long	Fail Sound Period (x 10ms), Set 0 to disable
M4	long	Stop Sound Period (x 10ms), Set 0 to disable
M5	long	Automatically Deactivate to Screen Saver The timer setting after Idle Condition(x 10ms), Set 0 to disable

APPENDIX B COMMAND LIST

M6	long	The setting is based on the combination of the following setting Display/Hide the second pressure 0x400; Switch the internal Pressure and External Pressure 0x200 Alternative Location 0x100; Temperature Reading 0x08; Enable remote command start/stop 0x20; 0:Disable, 1:Enable Enable DIO start/stop 0x10; 0:Enable, 1:Disable Start Button 0x04 Type Button 0x02 Stop Button 0x01
M7	Long	Brightness (1-255)

B10 O Group

Command	Type	Phase Valve Configuration
O1...OE	Integer	The last byte will be configured as follows: Clamp 0x80 Pres/Test 40 Exhaust 0x20 Fill/Balance 0x10 QuickFill 0x08 Isolate 0x04 Customer1 0x02 Customer2 0x01

B.11 P Group

Command	Type	Note
P1	float	PID Proportional Coef
P2	float	PID Integral Coef
P3	float	PID Differential Coef
P4	float	Flow Setting for flow control mode in selected flow unit.
P5	float	PID External Pressure Sensor usable criteria(%)

B.12 S Group

Command	Type	Note
S1	String	Serial Number: Up to 14 characters are allowed to enter. For example: <u>XX XX XXX XXX X XXX</u> 1 2 3 4 5 6 1 = Release of month, i.e. 06 = June 2 = Release of year, i.e. 98 = 1998

APPENDIX B COMMAND LIST

		3 = Serial No. – valid from 001 to 999 4 = Maximum Flow, i.e. 090=90, 120=120, 12H=1,200, 12K=12,000 5 = Flow Unit- C = CCM, L = LPM, U=ug/min, M=mm3/min 6 = Maximum Pressure in psia, i.e. 500=500 psia, 12H=1,200 psia, 12K=12,000 psia
S2	String	Read Only Return Version Number such as 020000 for version 2.0.0

B.13 T Group

Command	Type	Built-in Timers	Customized Timers
T1	Integer	Filling delay time in 10 ms	Step timer in 10ms
T2	Integer	Stability delay time in 10 ms	Ditto
T3	Integer	Test time in 10 ms	Ditto
T4	Integer	Clamping delay time in 10 ms	Ditto
T5	Integer	N/A	Ditto
T6	Integer	N/A	Ditto
T7	Integer	N/A	Ditto
T8-TE	Integer	N/A	Ditto

Note: All T group settings are defined as long integer (32 Bit) since Ver 2.1.3.

B.14 U-Group

Command	Type	Note
U1	Integer	Address 1-9
U2	Integer	Mode: 4th Byte Sensor Type Conventional Leak Tester 0 Adaptive Leak Tester 1 Flow Controller 2 Mass Extraction Method 3 Steady state Predictor 4 3rd Byte 0x0 0 <u>1</u> <u>1</u> 0 0 <u>1</u> <u>1</u> Bit 0: When '1', Sensor is configured as Model XE

APPENDIX B COMMAND LIST

		<p>Bit 1: Reference Flow function</p> <p>Bit 2: Quick Reference Flow function</p> <p>Bit 4: When '1', Sensor is configured for 4th analog input</p> <p>Bit5: PID Pressure sensor selection, 0=Internal Pressure sensor, 1= External pressure sensor</p> <p>2nd Byte</p> <p>0x <u>1 1 1 1 1 1 1 1</u> 5 4 3 2 1</p> <p><i>1:Valve Control</i> Standard 0x0 (Disable C1, X2, X3, XA) Customized 0x1- 0xF</p> <p><i>2:Flow Calibration</i> One Set of Calibration 0 Two Set of Calibration 1</p> <p>3: Relative Measurement</p> <p>4: Digital Input Pulse/Level Set to 1 if Level detection is desirable</p> <p>5: Vacuum Testing Message 1—Vacuum</p> <p>1st Byte</p> <p>Bit 0: Measurement Unit Mass Flow Base 1 μg/min as Base Unit Volume Flow Base 0 cc/min as Base Unit</p> <p>Bit 1: Gas Compensation Gas Compensation 1 No Coef Compensation 0</p> <p>Bit 2: 3rd Test Type On</p> <p>Bit 3: 3rd and 4th Test Type On Example: 0x00(1st byte) 27(2nd byte) 00(3rd byte) 02(4th byte)</p>
U3	Integer	Temperature Unit: 0-Degree C 1-Degree F
U4	Integer	Pressure Unit: Pressure Unit:

APPENDIX B COMMAND LIST

		<p>0- kPa 1-kg/cm2 2-psia 3-inHg 4-inH2O 5-psig 6-Torr 7- KPA-G 8- Bar-a</p>
U5	Integer	<p>Flow Unit:</p> <p>High Nibble 0 - cc 1 – mm3 2 -liter 3-gal 4 -gram 5 -mg 6- µg</p> <p>Lower Nibble 0 -sec 1 -min. 2 -hour 3-SCCM etc.</p> <p>16*HighNibble+LowNibble</p> <p>Besides: 7*16+3-SCCM 8*16+3-SLM 9*16+3-SCFM</p> <p>7*16+4 SCCSe-6</p>
U6	Integer	<p>0: One string of response to SQ1 command 1: two string of response to SQ1 command</p>
U7	Integer	<p>Baud Rate:</p> <p>0, and else: 9600 2:19200 4:38400 12:115200</p> <p><u>The Parameter will take effect after the power reset of the sensor</u></p>
U8	Integer	<p>Hold Value Time in U8*10 ms</p>

APPENDIX B COMMAND LIST

U9	Integer	Set U9 =0 to disable the some of the special features. 1) Disable Relative Measurement 2) Disable Mass Extraction Test 3) Disable Early Detection for Adaptive Test																				
UA	Integer	Start Cycle Counter. Cycle number can be shown on system and maintenance screens.																				
UB	Integer	Reference flow function flag. 1 Byte Within each byte of the above value the bit positions are numbered as shown: <table border="1" style="margin-left: 20px;"> <tr> <td>7</td><td>6</td><td>5</td><td>4</td><td>3</td><td>2</td><td>1</td><td>0</td> </tr> </table> <table border="1" style="margin-left: 20px; border-top: 2px solid black;"> <thead> <tr> <th style="background-color: black; color: white;">Bit #</th> <th style="background-color: black; color: white;">Description</th> </tr> </thead> <tbody> <tr> <td style="text-align: center;">0</td> <td>Reference Flow Activate: 0 = Reference Flow disabled from setup 1 = Reference Flow Enabled from setup</td> </tr> <tr> <td style="text-align: center;">4</td> <td>0 = TT1 Reference Flow activated if it is enabled 1= TT1 Reference Flow deactivated</td> </tr> <tr> <td style="text-align: center;">5</td> <td>0 = TT2 Reference Flow activated if it is enabled 1= TT2 Reference Flow deactivated</td> </tr> <tr> <td style="text-align: center;">6</td> <td>0 = TT3 Reference Flow activated if it is enabled 1= TT3 Reference Flow deactivated</td> </tr> <tr> <td style="text-align: center;">7</td> <td>0 = TT4 Reference Flow activated if it is enabled 1= TT4 Reference Flow deactivated</td> </tr> </tbody> </table>	7	6	5	4	3	2	1	0	Bit #	Description	0	Reference Flow Activate: 0 = Reference Flow disabled from setup 1 = Reference Flow Enabled from setup	4	0 = TT1 Reference Flow activated if it is enabled 1= TT1 Reference Flow deactivated	5	0 = TT2 Reference Flow activated if it is enabled 1= TT2 Reference Flow deactivated	6	0 = TT3 Reference Flow activated if it is enabled 1= TT3 Reference Flow deactivated	7	0 = TT4 Reference Flow activated if it is enabled 1= TT4 Reference Flow deactivated
7	6	5	4	3	2	1	0															
Bit #	Description																					
0	Reference Flow Activate: 0 = Reference Flow disabled from setup 1 = Reference Flow Enabled from setup																					
4	0 = TT1 Reference Flow activated if it is enabled 1= TT1 Reference Flow deactivated																					
5	0 = TT2 Reference Flow activated if it is enabled 1= TT2 Reference Flow deactivated																					
6	0 = TT3 Reference Flow activated if it is enabled 1= TT3 Reference Flow deactivated																					
7	0 = TT4 Reference Flow activated if it is enabled 1= TT4 Reference Flow deactivated																					

B.15 V Group

Command	Type	Note
V1	float	Min. Flow Alarm for leak test mode in cc/min, µg/min or selected unit based on X6.
V2	float	Max. Flow Alarm for leak test mode in cc/min. or selected unit based on X6. For mass extraction method, Max. Leak Alarm for leak test mode in cc, µg, or selected unit based on X6
V3	float	flow compensation to DP in kPa/(cc/min) or kPa/(µg/min)
V5	float	Min. Flow Alarm for Relative Measurement BaseLine Flow in cc/min, µg/min or selected unit based on X6.
V6	float	Max. Flow Alarm for Relative Measurement BaseLine Flow in cc/min. or selected unit based on X6.
V7	float	Large Leak Flow Alarm Flow in cc/min. or selected unit based on X6.

APPENDIX B COMMAND LIST

B.16 X Group

Command	Type	Note
X1	Integer	Pressure Switch On Check Step No Lowest Byte=Step No <i>2nd Lowest<>0, Advance to the next step once the PS is on (ver 2.1.1)</i>
X2	Integer	Pressure Switch Off Check Step No Lowest Byte=Step No <i>2nd Lowest<>0, Advance to the next step once the PS is off (Ver 2.1.1)</i>
X3	Integer	Leak Check Step
X4	Integer	Buffer Size: Valid from 4 to 100
X5	Integer	Enable Flag: Deplete the pressure after the test failure
X6	Integer	Default unit is used if X6 <>0 Flow in cc/min or µg/min. pressure in kPa and temperature in Degree C
X9	Integer	Flow baseline Step No
XA	Integer	Stop Test Step No
XB	Integer	LargeLeak Test Step No (<i>ver 2.1.2</i>) Lowest Byte=Step No <i>2nd Lowest<>0, The steps before and on LargeLeak will be set based on K5 and check against K6 and K7 3rd Lowest<>0, the step on LargeLeak will check against V7 as Minimum Large Flow (Version 2.37)</i>
XC	Integer	<i>Basic Check (ver2.2.0) Each bit of the integer representing the step in which the basic check shall be enforced. The Basic Check verifies the sensor is not saturated and pressure is not out of settings (P_{Hi} and P_{Lo}). "XC" Note: 1. If XC was set such as 0xFF, the gross leak check will be disabled. 2. Any basic step check after leak check step will be ignored! Example of setting: XC=0x06 In step 2 and step 3 the basic check will be enforced.</i>
XD	Integer	External Pressure On Step No Lowest Byte=Step No <i>2nd Lowest<>0, Advance to the next step once the external pressure is in range</i>
XE	Integer	External Pressure Off Step No Lowest Byte=Step No <i>2nd Lowest<>0, Advance to the next step once the</i>

APPENDIX B COMMAND LIST

		<i>external pressure is out of range</i>
--	--	--

Note:

The following condition has to be met in order for the IGLS to function properly:

- $X1 < X3 < XA < X2$
- $XB < X9 < X3$
- $1 < X3$
- $1 < XB$

17 Y-Group

Command	Type	Note
Y1	float	Reference Flow the first point time parameters.
Y2	float	Reference Flow the second point time parameters.
Y3	float	Reference Flow the third point time parameters.
Y4	float	Reference Flow the fourth point time parameters.
Y5	float	Reference Flow the fifth point time parameters.

B.18 Z-Group

Command	Type	Note
Z1	float	Reference Flow the first point flow parameters.
Z2	float	Reference Flow the second point flow parameters.
Z3	float	Reference Flow the third point flow parameters.
Z4	float	Reference Flow the fourth point flow parameters.
Z5	float	Reference Flow the fifth point flow parameters.

NOTE:

Commands implemented in 2.0.0 or later ONLY are in bold.
--

APPENDIX C Quick Reference Flow setting process

The quick reference flow setting function must be activated via Leak-Tek before it can be set on the sensor. After it is activated, user can follow the below steps to set the reference flow:

1. Power off the IGLS;
2. Connect the IO extension box if no start stop IO is accessible;
3. Hold the start and stop IO at the same time and power on the sensor, keep holding start and stop for at least one second;
4. For E2 or IPE2, the message "Reference Flow teach Mode" will be shown on the top of the LCD screen, for EPDQ, the Pass and Fail indicators will both on.
5. Run a test with a mast part and closed orifice.
6. If it success, one message "Reference Flow set success" will display on the top of the LCD screen and it will gone if start a new test.

In order to get the successfully set, the reference flow must smaller than the 10% of the full scale of the sensor, that means the AD count cannot over 6,553, else the set is failed and a message " RF Set Fail, ADC too High" will be shown on the top of LCD instead of the successful message. If it failed, the user needs to repeat all the steps above to set the reference flow again.

APPENDIX D - Specification Sheet

MODEL NUMBER: _____

S.N.: _____

SOFTWARE VERSION: _____

FLOW RATE: _____ CC/MIN. _____ LIT/MIN. (Fill One)
10% to 100% of volumetric flow range

FLOW MEASUREMENT UNCERTAINTY: +/- _____ % OF READING

PRESSURE RANGE: _____ PSIA

MAXIMUM PRESSURE: _____ PSIA

MAXIMUM PRESSURE DIFFERENTIAL CONTINUOUS: _____ PSID

STATIC: _____ PSID

PRESSURE MEASUREMENT UNCERTAINTY: +/- 0.2% OF FULL SCALE AT
OPERATING TEMPERATURE.

TEMPERATURE OPERATING RANGE: 10 - 45°C

TEMPERATURE MEASUREMENT UNCERTAINTY: +/- 0.5°C WHEN GAS FLOW IS AT
STEADY STATE OF CONDITION

For indoor use only; For use in altitudes up to 2,000m; Maximum relative humidity 80% for
temperatures up to 31 degrees decreasing linearly to 50% relative humidity at 40 degrees C;
MAINS supply voltage fluctuations up to +/- 10% of the nominal voltage; transient overvoltage is
impulse withstand (overvoltage) category 2 of IEC60364-4-443; Pollution degree of device is 2.

NOTE:

All uncertainty statements are at a 95% confidence level, referenced to primary standards traceable to NIST. Uncertainty statements comply with ANSI/NCSL Z520-Z-1997 "US guide to the expression of uncertainty in measurement".

APPENDIX E - IGLS Application Setup Example

Large Volume Setup with Large Flow Example:

Description	Time (sec)	Parameter
Clamping Delay	1	T4=40
Pre Fill Delay	4	T7 = 160
Fill Delay	200	T1=8000
Stability Delay	200	T2=8000
Test Delay	10	T3=400

Figure D.1 - Test Time Setting

Description	Setting	Parameter
Proportional	2000	P1=2000
Integral	400	P2=400
Differential	1	P3=1

Figure D.2 - PID Coefficient

Description	Enabled	Disable
Deplete After Failure	X5=1	X5=0

Figure D.3 - Valve Setting

Description	Setting(kPa)	Parameters
Pressure Setting	200	K1=200
Pressure Upper Limit	210	K2=210
Pressure Lower Limit	190	K3=190

Figure D.4 - Pressure Setting

Description	Setting(cc/min)	Parameters
Flow Min.	-1 (Disabled)	V1=-1
Flow Max.	1000	V2=1000

Figure D.5 - Flow Criteria

APPENDIX F – MODEL E2 OR MODEL VE2 ASSEMBLY DRAWING

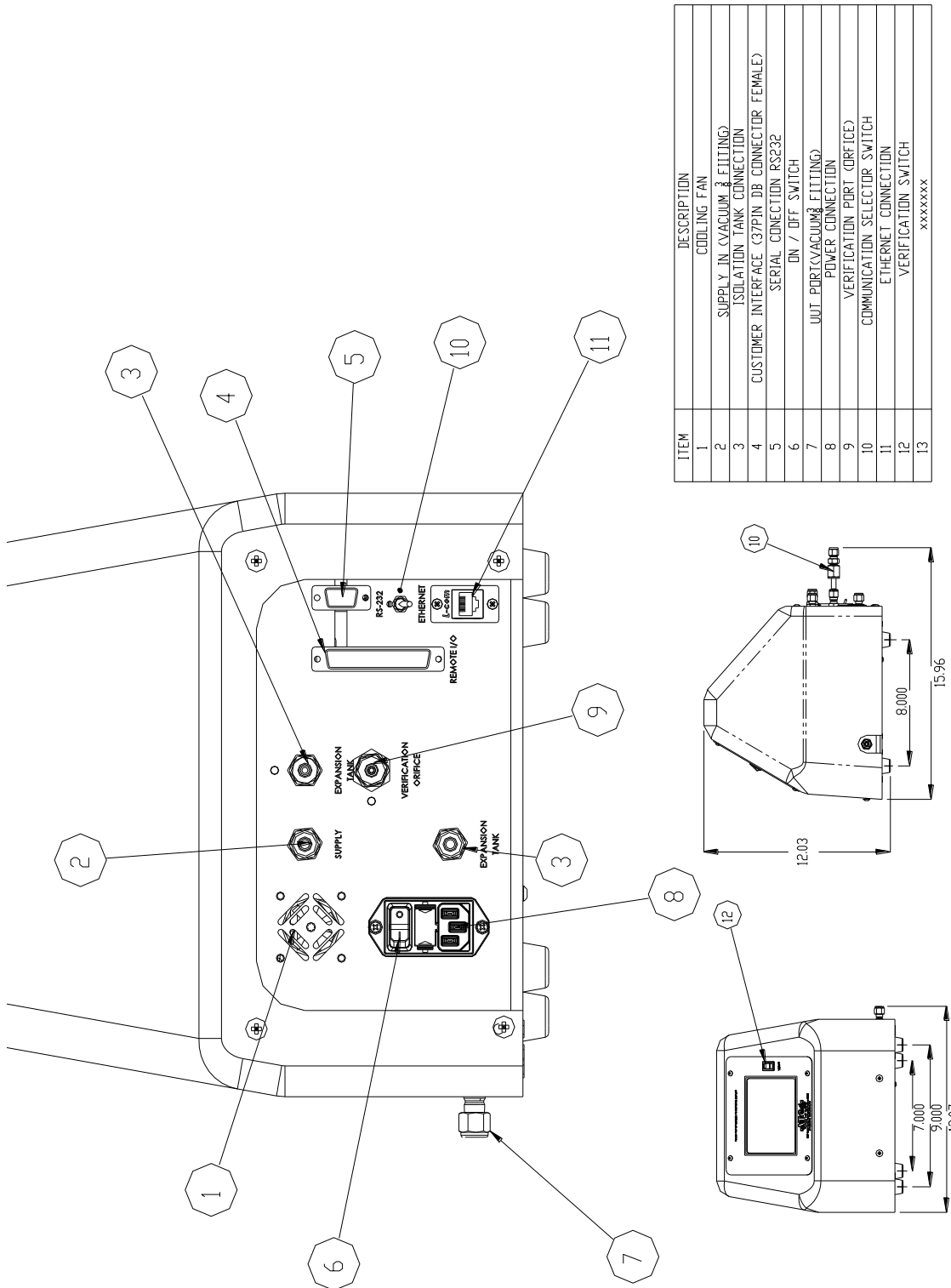

ITEM	DESCRIPTION
1	COOLING FAN
2	SUPPLY IN (VACUUM FITTING)
3	ISOLATION TANK CONNECTION
4	CUSTOMER INTERFACE (37PIN DB CONNECTOR FEMALE)
5	SERIAL CONNECTION RS232
6	ON / OFF SWITCH
7	UNIT PORT (VACUUM FITTING)
8	POWER CONNECTION
9	VERIFICATION PORT (ORFICE)
10	COMMUNICATION SELECTOR SWITCH
11	ETHERNET CONNECTION
12	VERIFICATION SWITCH
13	xxxxxxx

ALL FITTINGS 1/4 SWAGELOK COMPRESSION EXCEPT NOTED

Figure E.1 – MODEL E2 ASSEMBLY

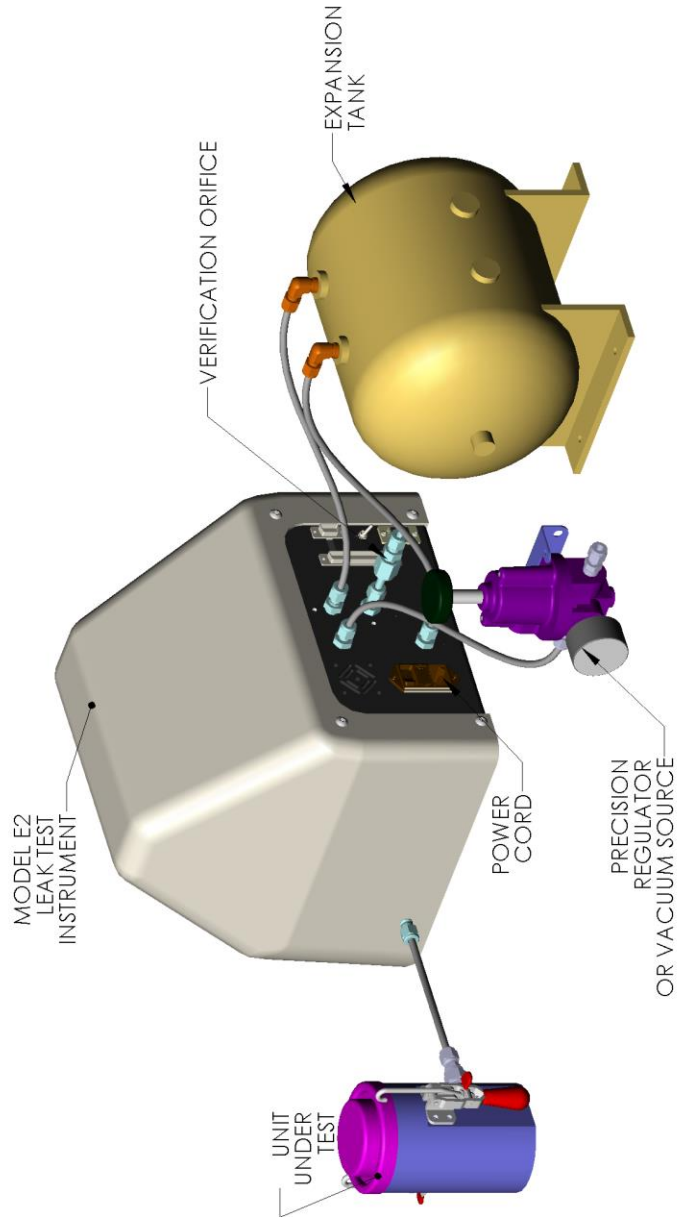
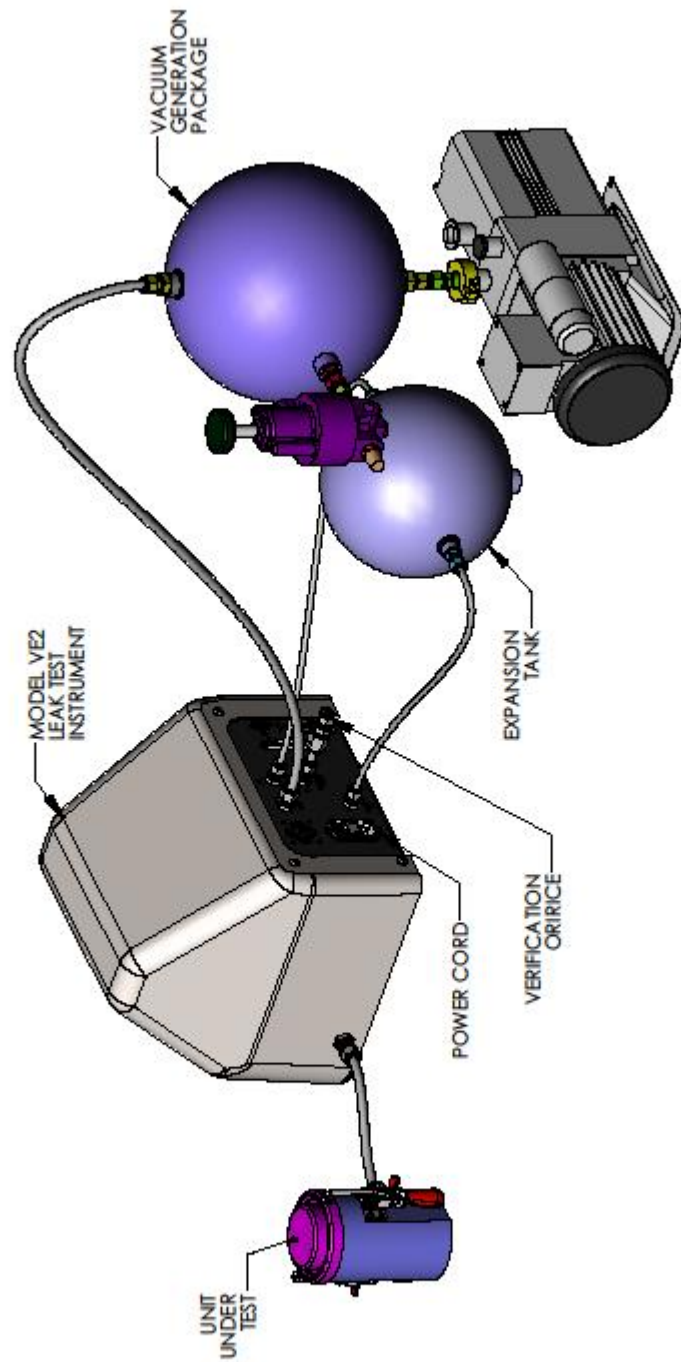

Figure E.2 – MODEL VE2 ASSEMBLY

APPENDIX F MODEL E2 OR MODEL VE2 CONNECTIONS, WIRING DIAGRAM NPN, PNP



APPENDIX G – MODEL E2 CONTROL ALGORITHM

The leak test control algorithm is as follows:

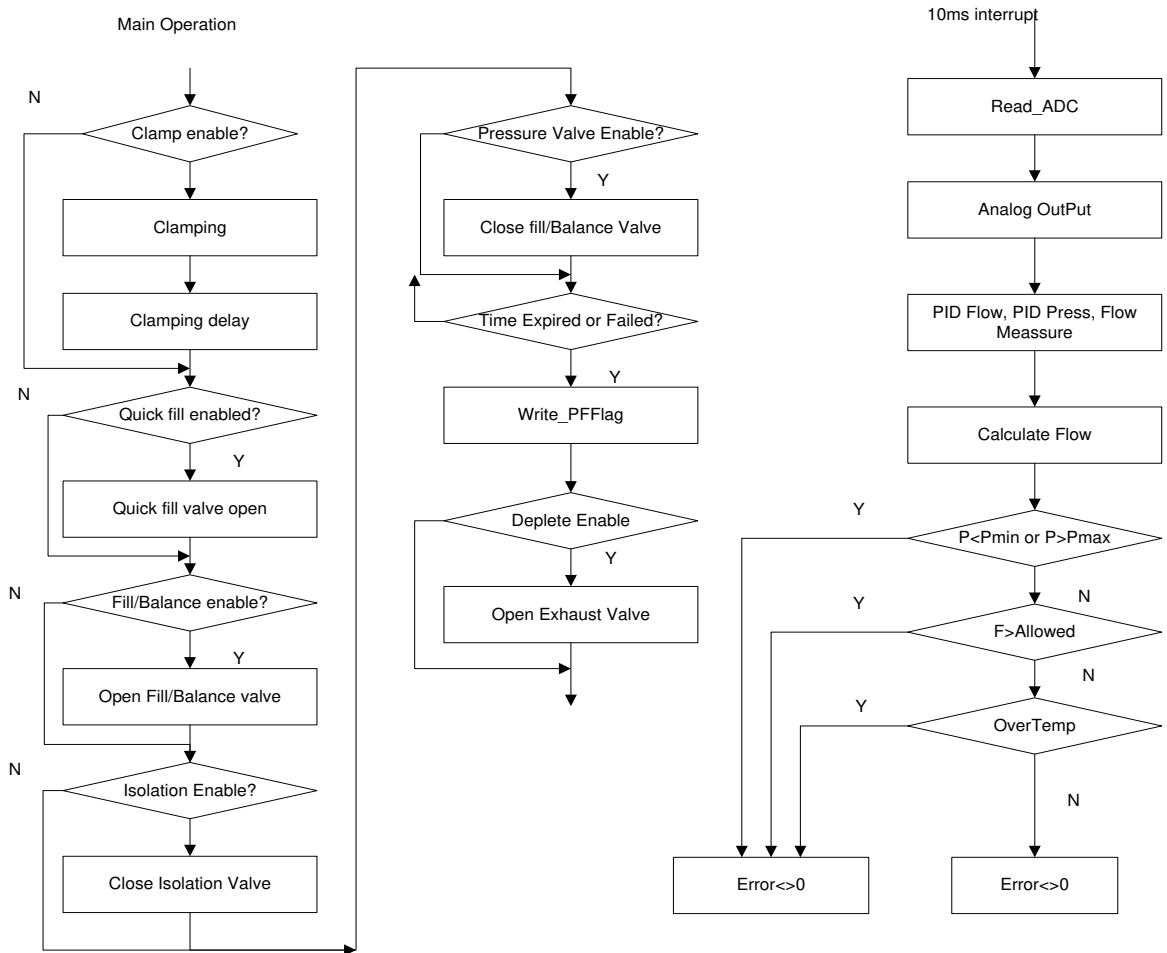

Figure F.1 Leak test control algorithm

The Mass Extraction test control algorithm is as follows:

Main Operation

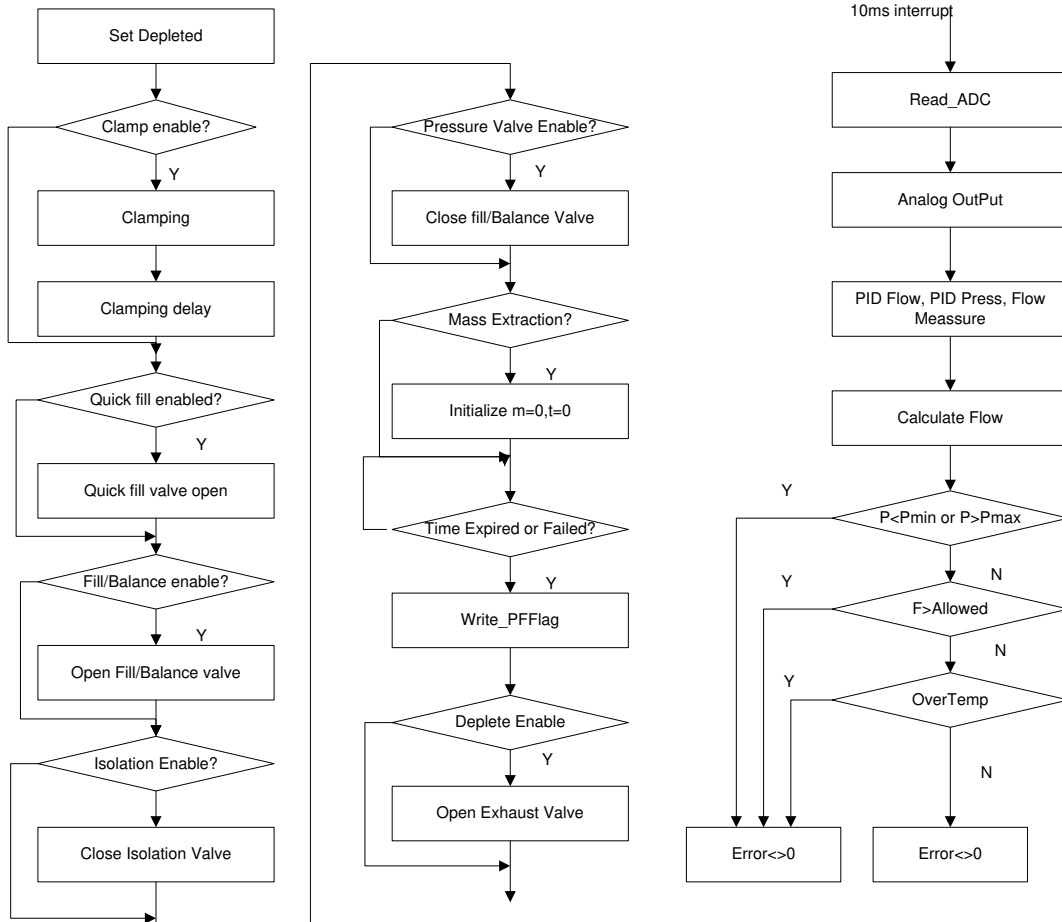

Figure F.2 Mass extraction test control algorithm