

Programming and Operation Manual

Leak Test Instrument Model ME2

Firmware Software Revision – 2.3.16
21 March 2022
Manual Revision 1.18

PROPRIETARY (Confidentiality) NOTE:

The IGLS (Intelligent Gas Leak System), IGFS (Intelligent Gas Flow Standard), IMFS (Intelligent Molecular Flow Sensor) and Mass Extraction Technology and Adaptive Test program are proprietary products belonging to ATC Inc., and protected by US Patent No.'s 5861546, 6308556B1, 6584828B2, & 6854318B2; 7,231,811B2. Other US and International patents pending. The Adaptive Test © feature and its set up tool program has a patent pending. The Leak-Tek © Program and ATC Model ME2 © are protected by international copyright laws. © 1995-2008 ATC Inc., All rights reserved.

(Rev 1.12 Includes Documentation on CE and RoHS conformity)

TABLE OF CONTENTS

TABLE OF CONTENTS	II
TABLE OF FIGURES	I
1. INTRODUCTION	1
1.1 Principle of Operation	2
1.2 Options	4
1.2.2 <i>High Pressure test circuit (optional)</i>	4
2. FUNCTION CONFIGURATION	5
2.1 Mass Extraction Leak Test/Closure Integrity	5
3. INTERFACE	6
3.1 BASIC CHANNEL OPERATION, MECHANICAL INTERFACE AND CONNECTION of the Model ME2	6
3.2 ENVIRONMENTAL CONDITIONS	9
3.3 ELECTRICAL INTERFACE AND CONNECTION	10
3.4 GUIDELINES FOR PNEUMATIC INTERFACE	16
3.4.1 <i>Purpose:</i>	16
3.4.2 <i>Common rules for upstream interface:</i>	16
3.4.3 <i>Leak Testing vacuum supply requirements:</i>	17
3.4.4 <i>High Pressure test circuit (where applicable):</i>	17
3.5 Guideline for Fixture Design	17
3.6 Guidelines for setting up Model ME2 Leak Tester	20
3.7 Verification Procedure	21
3.8 Accessories for Safe Operation	22
4. IMFS-MODEL ME2 OPERATION SEQUENCE	22
5. GRAPHIC LCD DISPLAY & TOUCH SCREEN	27
6. COMMUNICATION PROTOCOL	31
6.1 Conventional Commands for Sensor Parameters	31
6.2 DAQ Commands	31
6.3 Step Number	35
7. MAINTENANCE AND TROUBLESHOOTING	38
7.1 Periodic Maintenance and Calibration	38
7.1.1 <i>Filter</i>	38
7.1.2 <i>Periodic Calibration</i>	38
7.1.3 <i>System performance Verification</i>	39
7.2 Troubleshooting	40
APPENDIX A - CALCULATION ALGORITHM	46
APPENDIX B - COMMAND LIST	48
B.1 A Group	48
B.2 B Group	48
B.3 C-Group	49
B.4 D Group	49

B.5 G Group	49
B.6 H Group	50
B.7 K Group	50
B.8 L Group.....	50
B.9 M Group	51
B10 O Group.....	51
B.11 P Group.....	52
B.12 S Group.....	52
B.13 T Group.....	53
B.14 U-Group.....	53
B.15 V Group	56
B.16 X Group	56
B.17 Y-Group.....	58
B.18 Z-Group	58
APPENDIX C - QUICK REFERENCE FLOW SETTING PROCESS	59
APPENDIX D - SPECIFICATION SHEET	60
APPENDIX E - IGLS APPLICATION SETUP EXAMPLE	61
APPENDIX E – ME2 DIMENSIONS.....	62

TABLE OF FIGURES

FIGURE 3.1.1 - PNEUMATIC CONNECTION.....	8
TABLE 3.3.1.....	10
TABLE 3.3.2.....	10
FIGURE 3.2.1 – REAR PANEL STANDARD REMOTE I/O CONNECTIONS	13
FIGURE 3.2.2 – STANDARD REMOTE I/O PIN CONNECTOR.....	14
FIGURE 3.2.3 - LIST OF PASS AND FAILURE MODE WITH PIN OUTS.....	15
FIGURE 3.2.4 - SERIAL LOOP CONNECTION OF TWO MODEL ME2 INSTRUMENTS.....	16
FIGURE 3.5.1: SURFACE SEAL DESIGN WITH STATIC O-RING. NOTE: TOP PLATE CONTACTS THE PART TO PROVIDE HARD STOP AND MOVEMENT DURING TEST.....	19
FIGURE 3.5.2 CHAMBER SEAL DESIGN USING O-RING. SEAL PLATE CONTACTS THE PART, TO PROVIDE HARD STABLE STOP. (NOTE: SEAL DOES NOT SEAL ON THE INTERNAL BORE.).....	19
FIGURE 3.5.3 EXPANDABLE SEAL DESIGN – SEAL EXPANDS AS SEAL PLATE MOVES DOWNWARD. SAME CONCEPT CAN ALSO BE APPLIED TO ODS. SEAL PLATE CONTACTS THE PART TO PROVIDE STABLE HARD STOP.....	20
FIGURE 5.1 - MODEL ME2 CONTROL PANEL.....	27
FIGURE 5.2 - MODEL “ME2” LCD ELEMENT	29
FIGURE 5.3 - LCD DISPLAY WITH EXTERNAL PRESSURE SENSOR REPLACING INTERNAL PRESSURE SENSOR DISPLAY.....	30
FIGURE 6.1 - STEP NUMBER INTERPRETATION	37
FIGURE 7.2.1 - TROUBLESHOOTING	45
FIGURE D.1 - TEST TIME SETTING.....	61
FIGURE D.2 - PID COEFFICIENT	61
FIGURE D.3 - VALVE SETTING	61
FIGURE D.4 - PRESSURE SETTING	61
FIGURE D.5 - FLOW CRITERIA	61
FIGURE E.1 – DIMENSIONS OF ME2.....	62

WARNING:

This product deals with gas that will expand under pressure. Pressurized volumes (components, hoses, etc.) should be handled with proper protection to avoid any harm to the user.

WARNING:

This product is supplied with a power supply fed with 115 VAC or 230 VAC, single phase. When handling high voltage, use proper care to avoid harm to personnel and equipment due to electrical shock.

WARNING:

Use this product for the purpose of leak testing or flow measurement and testing in the pressure ranges and temperature ranges specified, ONLY!

WARNING:

Only qualified personnel should install, or use this product. Installation must comply with the manual requirements and product specifications.

WARNING:

Under no circumstances should the operator tamper with the “unit under test (UUT)” while the test is on. This may result in bodily injury and/or erroneous results.

WARNING:

This product shall be used for leak test application and/or flow measurement applications only.

WARNING:

When this Leak Test Instrument is part of a leak test system, it is the user’s responsibility to assure proper interface and maintenance in order for this instrument to utilize its measurement capabilities safely and accurately.

CAUTION:

This leak Test Instrument measurement reflects the momentary leak flow rate of the unit under test as presented to this instrument, at the test conditions and environment used. It is not a guarantee for “leak-free” products over long periods of time that are used in a different condition and environment.

CAUTION:

The user should be familiar with flow, pressure and temperature measurement units before setting up the leak test instrument. It is the user’s responsibility to properly define leak flow rates and tolerances for a specific application.

NOTE:

FUSE RATING: Incoming 120 VAC or 230 VAC supply is recommended to be fused at 10A at 120 VAC and 5A at 230 VAC for overcurrent protection.

CAUTION:

For 120 VAC rated products, incoming supply outside 120 VAC +/-10% and unable to source 10 Amps is NOT recommended and may result in inaccurate results, product malfunction and/or damaged electronics.

For 230 VAC rated products, incoming supply outside 230 VAC +/-10% and unable to source 5 Amps is NOT recommended and may result in inaccurate results, product malfunction and/or damaged electronics.

EU DECLARATION OF CONFORMITY

1. Produce model / Product:

Product Micro-Flow Leak and Flow Test Instrument
Model/Type RD31/ME2/M2 and all variants/options associated with this model

2. Manufacturer:

Manufacturer Pfeiffer Vacuum Incorporated
Address 4037 Guion Lane
Indianapolis, IN 46268
317-328-8492
USA
www.pfeiffer-vacuum.com

3. This declaration of conformity is issued under the sole responsibility of the manufacturer.

4. Object of the declaration:

Product An electro-mechanical instrument for detecting micro-flow leaks

5. The object of the declaration described above is in conformity with the relevant Union harmonization legislation:

2011/65/EU The Restriction of Hazardous Substances Directive
2014/30/EU The Electromagnetic Compatibility Directive
2014/35/EU The Low Voltage Directive

6. References to specifications in relation to which conformity is declared:

IEC 61010 1:2010/AMD1:2016 Safety Requirements for Electrical Equipment for Measurement, Control, and Laboratory Use
EN 61326 1: 2013 Electrical equipment for measurement, control and laboratory use – EMC requirements

7. The technical file is available from the manufacturer at the address above

Signed for and on behalf of: Pfeiffer Vacuum Incorporated
Place of issue: USA
Date of issue: 14th June 2021
Name: Derek Izzi
Position: General Manager
Signature:



1. Introduction

This manual applies to the operation and maintenance of the Leak and/or Flow Test Instrument Model ME2 incorporating ATC's patented Micro-Flow technology, Intelligent Molecular Flow Sensor (IMFS) and the Mass extraction Technology (ME) manufactured by:

Advanced Test Concepts
4037 Guion Lane
Indianapolis, IN 46268
317-328-8492
www.atcinc.net

The IMFS sensor is a micro-flow gas (typically AIR) sensor operating based on ATC's patented micro-flow sensor design and operating at hard vacuum (0.5 – 5 torr in the transitional and/or molecular flow regime) with an integrated valve manifold ⁽¹⁾. The IMFS electrical signal is proportional to Mass Flow (at these pressure/vacuum ranges) and therefore it measures mass flow. A built-in pressure and temperature sensors measure Vacuum and Temperature. The instrument measures mass flow and can display calculated volume flow at actual or std. conditions - by selecting one of 27 flow units and their combinations. The IMFS has a microprocessor-based flow computer and controller. The flow computer program performs on board mass (e.g., $\mu\text{g}/\text{min.}$) flow measurements. The flow computer can total the flow (i.e. total mg) during testing using the total mass extraction concept. The IMFS has the capability to control valve sequencing required for a complete stand-alone leak test.

The IMFS monitors its flow regime, and will indicate if operates outside of the allowed flow regimes. When switching to higher pressure (lower vacuum level e.g: 100 torr) different calibration coefficients needs to be set by ATC to adjust for the different sensor characteristics along with possible hardware changes.

The touch screen graphical LCD display includes start, stop, and test select buttons, measurement reading, and flow signature graph.

The IMFS sensor measures leak flow rates based on the mass conservation law using ATC's Mass Extraction method. Mass Extraction methods based on measuring the amount of flow extracted (flow rate or accumulated mass) required to maintain constant vacuum at a constant temperature equal to the amount of flow "leaking in". This method offers a quick test time without sensitivity to unit under test (UUT) volume, part temperature, etc..

A separate software (optional, and may not be included with this product) with a Graphical User Interface (GUI), the Leak-Tek[®] program, can be used in conjunction with the IMFS sensor. The Leak-Tek program allows the user to configure desired parameters to meet specific requirements, and can be used to download to the IMFS as well as view, save, and analyze test data using a PC. Consult ATC's Leak-Tek program[®] manual.

INTRODUCTION

ATC's patented Adaptive Test ⁽²⁾ feature can be used with this product to "teach" a typical part signature and dynamically predict UUT leak rate (based on real time statistical considerations) to save cycle time. Consult ATC's Adaptive Test Utility program© manual for more details.

The IMFS and ME2 instrument receives commands and data requests, and returns data via a bi-directional RS-232 port or Ethernet. The Model ME2 includes a female 9-pin D-connector on the side panel for connecting to a PC using a straight through RS-232 serial extension cable. The Model ME2 also includes an RJ45 Ethernet connector on the side panel for connecting to a PC via a network connection either directly to a PC or through a LAN. Selection of the communication method is made via the COMM SELECT toggle switch located inside the Model ME2 enclosure. Only one communications port may be used at any time. The Ethernet connection does not support multiple users access to the Model ME2. Refer to the Operator Manual for Leak-Tek © program version 5.0 or later for network setup and instrument configuration when using the Ethernet communications port.

Extensive programming commands allow the user to address any one of the connected sensors in order to configure the selected sensor, update the calibration data, and establish new test parameters.

Depending on the Model type, the instrument can be configured to run up to either two (2) or four (4) types of tests without downloading new parameters for applications with more than one test type. Test type can be selected via the front panel graphical LCD display, or remotely via the side panel connections. All remote or external controls (input or output) are available at the male 37-pin D-connector on the side panel of the Model ME2.

1.1 Principle of Operation

The Leak Test Instrument, Model ME2 with IMFS and integrated valve manifold and its accessories provide a complete solution for leak flow testing. The leak testing concept is based on the mass conservation law. Per this basic law of physics, once the UUT is evacuated and reaches steady state condition (stable vacuum and temperature), the amount of AIR mass flow extracted from the UUT equals the amount of mass flow that leaks in. In other words, the IMFS sensor measures the make-up flow required to keep the vacuum steady in the UUT under evacuated condition.

Test can be configured by the user to perform one of the following configurations:

1. Vacuum is applied INSIDE the UUT. Air leaking into the part (UUT) from outside (at barometric condition or in a pressure chamber) is measured. In this case the ME2 instrument is connected to the UUT.
2. Part is placed inside a vacuum chamber and is pressurized. Air leaked into the vacuum chamber is extracted into the ME2 instrument. In this case the ME2 connected to a vacuum chamber.

INTRODUCTION

3. Part is placed inside a vacuum chamber and is an enclosed part (enclosed at barometric condition). Air leaked into the vacuum chamber is extracted into the ME2 instrument. In this case the ME2 connected to a vacuum chamber. This method also known as “Closure Integrity Testing”.

The advantage of the IMFS or mass extraction technology or mass extraction measurement is that the leak flow rate at steady state is independent of the UUT volume, and the measurement is a direct leak flow measurement. Therefore, very frequent calibration is not required, and standard annual calibration procedures are applicable. The supplied verification orifice (sometimes called “calibrated leak”) is used only to verify equipment operation, such as valve leakage, etc.

The Model ME2 utilizes valves with fixed orifices; therefore, testing large volumes with this instrument may require longer evacuation time. For these applications consult ATC. The IMFS technology offers a faster and very repeatable leak test. For short cycle time you can use the signature concept as described in the Leak-Tek software manual.

Part must be presented clean and dry. Water and materials with high vapor pressure will boil/evaporate at this vacuum level. This phenomenon is known in vacuum applications as “out-gassing”. If excessive out-gassing is experienced, the system can be configured/changed to operate at higher pressure – consult ATC.

Definitions:

(1) Micro-Flow Sensor: A flow sensor, including: a flow element defining a capillary flow path for permitting gas flow from the input conduit to the output conduit; a pressure sensor configured to measure a momentum and energy loss across the capillary flow path; wherein the flow sensor operates in a viscous, a slip, and /or a transition and/or a molecular flow regimes.

(2) Adaptive Test: Applying a pressure to the part, developing a gas flow through a sensor in response to the applied pressure and determining a dynamically predicted leakage flow-rate based upon actual measured leakage flow-rate over time. Concluding one of the gross leak and the insignificant leak is detected

1.2 Options

Some Model ME2 Instruments may come with the following option:

- 1 High Pressure test circuit with pressure switch.

1.2.2 High Pressure test circuit (optional)

The High Pressure test circuit is designed to pressurize and test the part proof pressure (max. pressure) before the ME2 IMFS vacuum test circuit is engaged to do leak test. In this method the part is placed in a chamber and the chamber or the part is pressurized. A pressure switch/sensor is used to determine if the part can hold the pressure. The test typically starts with a large / gross leak test, followed by part pressurizing, and the part holds the pressure then the ME2 and the IMFS circuit is engaged. Vacuum is then pulled from the inside or outside of the part or from the chamber. Any air leaking in from the pressurized section to the vacuum section is detected as leak.

2. Function Configuration

2.1 Mass Extraction Leak Test/Closure Integrity

When functioning as an automatic leak tester, the IMFS controls signals to the clamping valve, pressure/test valve, exhaust valve, evac/balance valve, quick evac valve, isolation valve, and up to one custom valve to evacuate the UUT and allow stabilization. The IMFS is configured with two analog outputs of 0-5 VDC.

After the stabilization time, the test begins. The IMFS will monitor flow readings for a pre-defined test time period and make a pass/fail determination based on pre-defined test criteria (pressure and flow must be within a pre-defined range to pass the test). It will automatically go to a standby condition at the end of the test if pass occurs. The re-test function can be configured to allow a continuous test until the pass criteria are met or until the stop button is pressed manually to stop the unit. The test status is displayed on the LCD. Test pass/fail criteria, test time, and stabilization time are configurable via the RS-232 port or Ethernet port using the Leak-Tek © program or hyper-terminal.

Refer to Appendix D for application examples. If the multiple test types feature is configured, it is possible to toggle between up to 4 test types using the front panel button or by supplying a control signal to the side panel D-connector (see figure 3.2.2 for pin outs).

In some situations, the leak may not be constant, may vary significantly during the test, or the UUT is a sealed volume, which cannot be pressurized. Therefore, the TOTAL mass extracted during test time would be the better test method. It accumulates (totals over test time) the leaks during the test period, and compares them to the maximum setting to make a decision of pass or fail.

Both configurations can be set via the Leak Tek program © once the IMFS is factory configured to perform the additional Total Mass Extracted measurement.

3. Interface

3.1 BASIC CHANNEL OPERATION, MECHANICAL INTERFACE AND CONNECTION of the Model ME2

WARNING:

If hazardous conditions and gasses result, consult ATC

WARNING:

The standard Model ME2 is NOT rated to operate in class 1 or 2 environment.

WARNING:

The fluids used should be gasses compatible with IMFS wetted material, which consists of stainless steel and Viton seals. Gasses currently supported are dry air, nitrogen, carbon dioxide, and helium. For other gases, consult ATC.

CAUTION:

The Model ME2 is supplied with a filter. Clean and maintain the filter and supply lines, as excessive contamination will cause distortion of readings.

CAUTION:

The operating temperature as well as the gas temperature should be from 10 to 45 °Celsius. For a higher temperature range, consult ATC.

CAUTION:

The maximum pressure applied to any ME2 unit air connection should not exceed 1 psig.

CAUTION:

It is the user's responsibility to assure that the UUT is present and properly connected before starting the leak or flow test. In the case of massive leak or test while test port is not connected, the user is responsible to allow enough time for the pressure to build up and stabilize in the supply expansion tank.

INTERFACE

NOTE:

Mount and locate the Model ME2 as close as possible to the UUT, to minimize Model ME2 UUT connection tube length and volume. Larger volumes will reduce system response to a given leak flow.

CAUTION:

Mount and locate the ME2 such that the 120 VAC or 230 VAC detachable power cord is accessible given the unit's power entry module location.

NOTE:

The ME2 unit is a precision micro-flow leak testing product. Routine maintenance and periodic recalibration is recommended only by ATC service technicians or by ATC authorized service professionals.

NOTE:

If the ME2 unit is not performing as expected, please contact ATC. Do not attempt to repair the ME2 without first contacting ATC, an ATC service technician or an ATC authorized service professional.

CAUTION:

If this equipment is used in a manner other than as specified in these operating instructions or other provided documentation provided by the manufacturer, protection from impairment may be defeated.

The Model ME2 include integrated manifold with air actuated manifold mounted valve controlled by the IMFS. IMFS controls an internal evac/balance valve, isolation valve, test valve, and exhaust valve, these valves are manifold mounted. It also controls standalone quick evac valve and an optional clamp/seal valve, custom valve and/or electronic pressure controller. The actuator Solenoid valves are used for automatic control. A verification orifice valve which is a part of the integrated valve manifold can be operated from the front panel controls. The pneumatic connection should be per the enclosed diagram (Figure 3.1.1).

A vacuum pump is used to generate the vacuum. The vacuum pump is connected to a mixing tank. A controlled amount of air is introduced through an orifice to the mixing tank to set the vacuum level. The optimize size of the vacuum pump and the mixing tank reduces the vacuum fluctuation to the Model ME2 and increase system performance and throughput.

INTERFACE

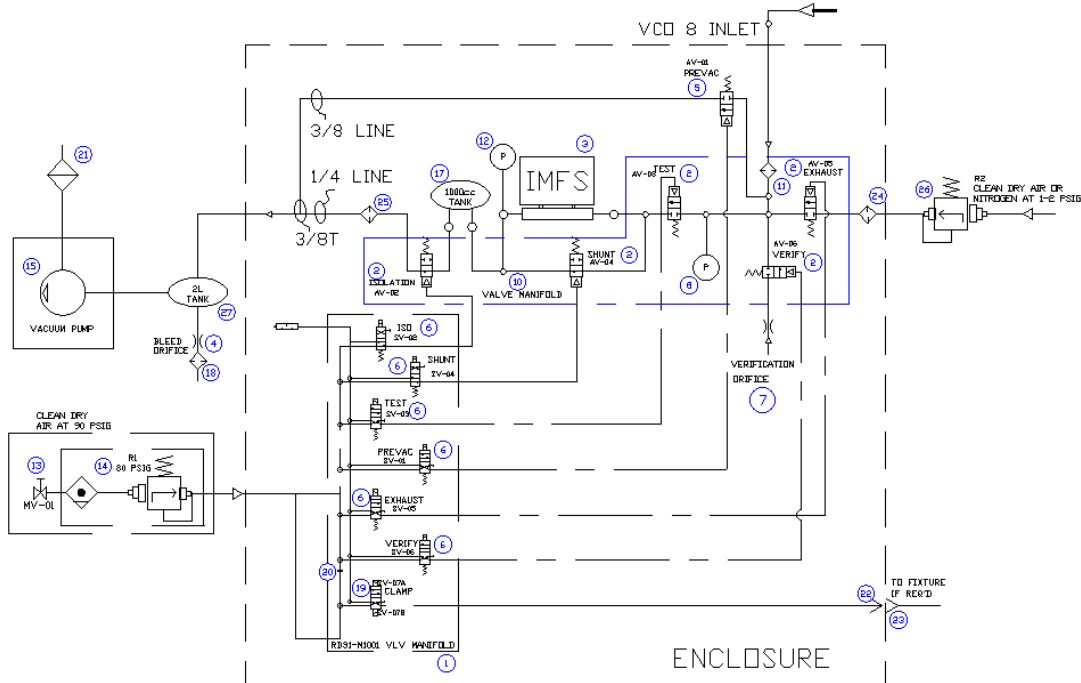

Figure 3.1.1 - Pneumatic Connection.

NOTE:

See Appendix E for outside dimensions.
For your application, see DRAWINGS section for details.

CAUTION:

Material selection and pressure ratings: Make sure that pneumatic interface components are compatible with the gasses. Make sure all components comply with appropriate codes for pressure ratings (such as ASME Boiler codes, SAE standards, etc.). Make sure that tubing and fittings meet leak specification of 10 times better than the rating of the instrument and leak test specification.

UUT Port connection: This port is typically on the top of the ME2 unit, typically VCO 4 or VCO 8. VCO fitting should be wrenched very lightly on the bulkhead by supporting the bulkhead fitting with an 11/16 or 1" wrench when tightening the tube, do not over tighten. Depending on specific customer needs other sizes of tubes may be utilized. Consult DRAWINGS section for more detail.

Vacuum inlet connections: These connections are typically on the left side of the instrument. Support the bulkhead fitting with 1" wrench when tightening the tube fitting (1/2" Swagelok ® tube fitting). Do not over tighten. Depending on specific

INTERFACE

customer needs other sizes of tubes may be utilized. Consult DRAWINGS section for more detail.

3.2 ENVIRONMENTAL CONDITIONS

The ME2 is designed for indoor use only.

The ME2 has been tested and evaluated to an altitude of 2000 meters. Contact ATC regarding any operating restrictions for the ME2 if operating above 2000 meters.

The ME2 operating relative humidity range is 80% for temperatures up to 31C and decreasing linearly to 50% relative humidity at 40C.

The ME2 supply voltage is either 120 VAC +/-10% or 230 VAC +/-10%. The ME2 model number will specify the 120VAC or 230VAC input voltage rating.

The ME2 is not designed to operate in wet or condensing environments.

The ME2 is designed to operate in a Pollution Degree 2 environment.

The ME2 is designed to the IEC overvoltage category II standard.

The ME2 product is heavy. ATC recommends that at least two people should be utilized to lift or to carry the ME2 unit. In addition, a suitable sturdy work surface should be utilized to support the ME2 unit's weight as well as all additional components that are utilized to perform micro-flow leak testing.

3.3 ELECTRICAL INTERFACE AND CONNECTION

The ME2 is supplied with a 120 VAC/230 VAC power entry module on its side. The ME2 units are rated as shown in Table 3.3.1

Table 3.3.1

Voltage	Current	Power
120 VAC	10 A (peak)	1200 W (peak)
230 VAC	5 A (peak)	1150 W (peak)

The ME2 unit is design to operate at 120 VAC at 60 Hz and 230 VAC at 50 Hz.

There are two replaceable fuses in the ME2 unit. Information regarding these replaceable fuses is shown in Table 3.3.2.

Table 3.3.2

Fuse Location	Fuse Component	Fuse Characteristics
Within the switched power entry component mounted on the side of the ME2 unit	120V: GMC8 230V: GMC4	Time Delay Glass
Within the ME2 unit within the electrical components area typically labelled "FU-6" which is typically a DIN rail mountable fuse holder typically mounted in the bottom left corner	120V: LPCC6 230V: LPCC3	Time Delay; Low Peak; Class CC

WARNING:

The Model ME2 is supplied with a power cord connected to 115VAC or 230VAC single-phase connector. Proper grounding and electrical practices should be used.

WARNING:

When maintaining or opening the Model ME2 enclosure, the supplied power should be disconnected.

WARNING:

After completing any maintenance or repair which required opening the ME2 enclosure, check all fuse operational status and check all fuse ratings prior to closing the ME2 enclosure.

INTERFACE

CAUTION:

The use of any detachable power cord not supplied with the ME2 has a risk of causing a safety issue which could cause personal and/or property damage or death.

WARNING:

The Model ME2 is supplied with a power cord for 115 VAC or 230VAC single phase power. Connect it to an AC connector that complies with local electrical codes.

CAUTION:

Improper power wiring will cause permanent damage to the unit.

NOTE:

All digital Inputs are optically isolated. Use only 5 VDC for inputs. Directly wire the inputs via a push button or dry contact. Do not use a solid state relay for the inputs.

NOTE:

Refer to detailed electrical drawings in the Electrical Drawing Sections. If there are any additional details or discrepancies, the electrical drawings prevail. Digital outputs do not have enough power to drive an inductive load. Use small external relays or optically isolated modules (preferred) to drive valves or large relays.

NOTE:

The ME2 Ethernet port does not support Power Over Ethernet (POE).

The male 37-pin D-connector located on the side panel of the Model ME2 is arranged as shown in Figures 3.2.1 & 3.2.2.

INTERFACE

Pin	Function	Specifications
Pin 1	Analog Output A	0-5 VDC
Pin 2	Analog Output B	0-5 VDC
Pin 3	Remote Exhaust Valve Output	Switched 12 VDC, 22W max
Pin 4	Remote Exhaust Valve Return	0 VDC
Pin 5	Ground/Common	0 VDC
Pin 6	Verify Input	5-30 VDC, source or sink*, 30 mA max.
Pin 7	Remote Output Common	5-30 VDC, source or sink*, 100 mA max.
Pin 8	Clamp Output	5-30 VDC, source or sink*, 100 mA max.
Pin 9	Pressure/Test Output	5-30 VDC, source or sink*, 100 mA max.
Pin 10	Exhaust Output	5-30 VDC, source or sink*, 100 mA max.
Pin 11	Evac/Balance Output	5-30 VDC, source or sink*, 100 mA max.
Pin 12	Quick Evac Output	5-30 VDC, source or sink*, 100 mA max.
Pin 13	Isolate Output	5-30 VDC, source or sink*, 100 mA max.
Pin 14	Analog Ground	0 VDC
Pin 15	Not used	
Pin 16	Not used	
Pin 17	Not used	
Pin 18	Not used	
Pin 19	Not used	
Pin 20	Not used	
Pin 21	CustoME2 Output	5-30 VDC, source or sink*, 100 mA max.
Pin 22	Pass Output	5-30 VDC, source or sink*, 100 mA max.
Pin 23	Fail Output	5-30 VDC, source or sink*, 100 mA max.
Pin 24	PFail Output	5-30 VDC, source or sink*, 100 mA max.
Pin 25	TTA Output	5-30 VDC, source or sink*, 100 mA max.
Pin 26	TTB Output	5-30 VDC, source or sink*, 100 mA max. Test Type1: TTA:1, TTB: 0 Test Type2: TTA:0, TTB: 1 Test Type3: TTA:1, TTB: 1 Test Type4: TTA:0, TTB: 0

INTERFACE

Pin 27	Start Input	5-30 VDC, source or sink*, 30 mA max. Apply a pulse to the sensor Start input pin to start a test
Pin 28	Stop Input	5-30 VDC, source or sink*, 30 mA max. Apply a pulse to the sensor Stop input pin to stop a test
Pin 29	Test Type Input	5-30 VDC, source or sink*, 30 mA max. Apply a pulse to the sensor Test Type input pin to switch to the other test type
Pin 30	Pressure Switch Input	5-30 VDC, source or sink*, 30 mA max.
Pin 31	Remote Input Common	5-30 VDC
Pin 32	Not used	
Pin 33	Not used	
Pin 34	Not used	
Pin 35	Not used	
Pin 36	Not used	
Pin 37	+5 VDC Power (DO NOT use to power external devices! Use only for Model E2 or Model VE2 digital inputs.)	+5 VDC
* Sinking or Sourcing is selected for all Inputs or Outputs as a group, i.e. all sinking inputs, all sourcing outputs, etc. Use pins 7 and 31 to select type and voltage of inputs and outputs.		

Figure 3.2.1 – Rear Panel Standard Remote I/O Connections

* If other custom options are purchased, see the drawings section in the back of this manual.

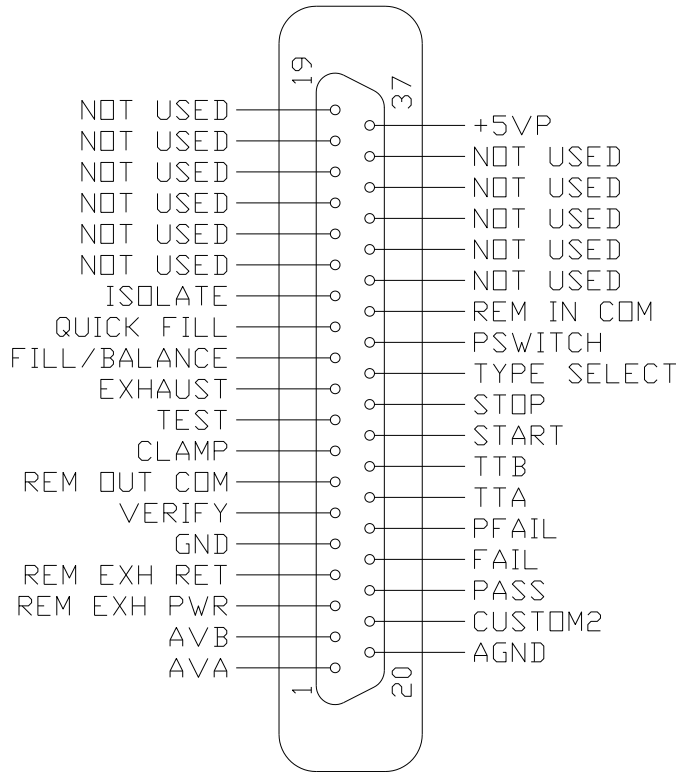

Figure 3.2.2 – Standard Remote I/O Pin Connector

Condition	Description	Pin out
Pass	The test met all criteria set in the set-up screen	Pin 22
Gross leak Fail	When vacuum is below the vacuum Min setting in pressure testing or pressure switch not turned on in during evac delay	Pin 23
Gross Leak Vacuum Fail	The vacuum Is Larger Than The vacuum Max setting in vacuum testing	Pin 23
Blockage Fail	Pressure switch not turned off at the end of the test during deplete time, External Pressure is within the limits for Ext Press Off action	Pin 23, Pin 24
Fine Leak Fail	Flow is above the maximum flow limit setting	Pin 23
Low Flow Fail	Flow is below the minimum flow limit setting	Pin 23
Back Flow	The Flow Sensor Detected the Flow in Opposite Direction or System leak check failure	Pin 23

INTERFACE

Over pressure	The vacuum Is Larger Than The vacuum Max Setting in pressure testing	Pin 23
Under pressure	When vacuum is below the vacuum Min setting in vacuum testing	Pin 23
Flow Saturation	Exceeding Flow Sensor Limit	Pin 23
Pressure saturation	Exceeding press Sensor Limit	Pin 23
Temperature saturation	Exceeding temperature Sensor Limit	Pin 23
PresRng-HI	External Pressure higher than set limit	Pin 23, Pin24
PresRng-Lo	External Pressure Lower than set limit	Pin 23, Pin 24

Figure 3.2.3 - List of Pass and Failure Mode With Pin outs

INTERFACE

Up to 9 Model ME2 instruments can be connected in a serial loop. A typical serial loop connection with two instruments is shown in Figure 3.2.4.

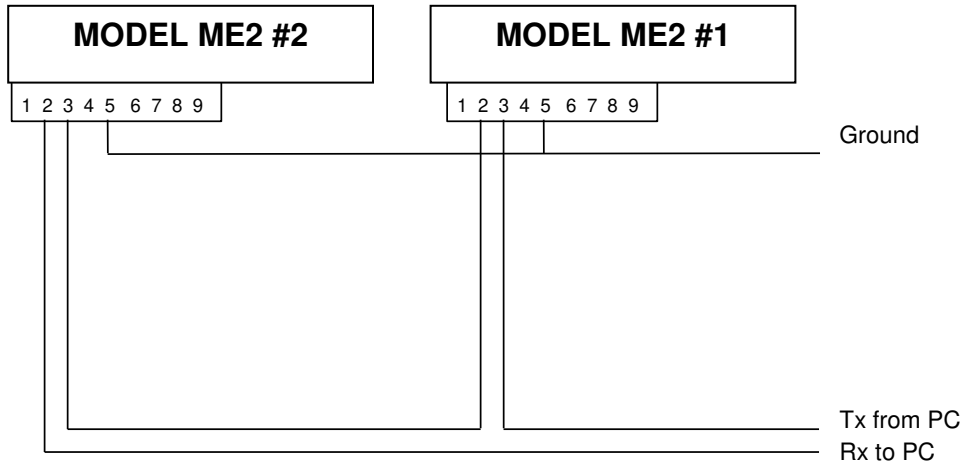

Figure 3.2.4 - Serial Loop Connection of two Model ME2 Instruments

* See DRAWINGS section at the end of the manual for details of Optional connections.

See the appendices for sample PLC program for remote automatic operation of the Model ME2.

3.4 GUIDELINES FOR PNEUMATIC INTERFACE

3.4.1 Purpose:

Proper pneumatic interface is important to ensure repeatable, reliable and safe leak testing. Supply vacuum fluctuations must be minimized recommended to use ATC's supplied vacuum generating system in order to ensure good system performance. Most Proper connections must be used to minimize system leak and reduce virtual leaks (leaks that flow into internal hidden cavities).

3.4.2. Common rules for upstream interface:

Upstream pressure fluctuations from pneumatic actuators and/or assembly tools are undesirable, and it might affect air supply to the actuator solenoid valves a large expansion tank is desirable.

- A. Air must be clean (10 micron filter) and dry (descent dryer) to protect the valves.
- B. No NPT or "push-in" fittings at test lines. Consult ATC if NPT must be used.

INTERFACE

- C. Use VCO or VCR fittings for low leak spec. test applications and vacuum applications (Mass Extraction), to minimize virtual leaks.

3.4.3 Leak Testing vacuum supply requirements:

Vacuum must be stable and air should be introduced to control the vacuum through an orifice. ATC typically supplies the vacuum generating system including the pump and the orifice.

Note: Consult ATC if vacuum generating system is user supplied.

3.4.4 High Pressure test circuit (where applicable):

- A. The test is performed at a high pressure (could be 2000 psig).
- B. Upstream regulator set to desired test pressure.
- C. Isolation pressure valve (2 way NC) and Exhaust valve (2 way NO) are required to isolate pressure source, once pressure is reached, and to quickly exhaust upon test failure.
- D. A pressure switch is needed to monitor for gross leaks.
- E. A carefully designed and constructed test chamber is required to perform the test- test chamber (user supplied) shall be designed with all applicable safety considerations.
- F. The fixture assembly should have two ports. One for the part and the other for the chamber.
- G. Connection lines are typically 1/2" or 3/4" (application dependent, TBD).

3.5 Guideline for Fixture Design

The following are recommendations regarding fixture design using ATC's leak test instruments and low-level leak testing. This is only a recommended guideline, based on ATC's prior experience using third party fixtures.

Note:

It is the user's responsibility to properly design the test fixture, test fixture control, electrical system and pneumatic interface for proper leak testing operation.

Caution:

Duplication of fixtures operating with under water or pressure decay leak test methods can result in lack of performance using ATC's micro-flow leak test methods, especially at low level leak testing.

Warning:

Fixture design and operation should comply with all safety requirements, especially when performing pressure tests. High forces can be easily generated with relative low pressure, but large sealing area.

- Ensure that all safety aspects are per code and in place during the fixture design, build and application. Ensure operator and maintenance personnel safety.

INTERFACE

- Mechanical fixture should provide stable volume. Fixture seal “drift” or movement during leak test will cause volume changes and bias of readings.
- Fixture and seal plate should be designed to have metal-to-metal contact with the UUT to prevent seal movement during test. Avoid adjustments that can drift or be tampered with (Figure 1 and 2).
- Seal mechanism should fit the application. For low leak rate applications, O-ring seal design (inside a dove-tail groove, Figure 1) approach should be considered. It requires tight true positioning of the sealing surfaces. Follow the O-ring “squeeze” requirements of the manufacturer.
- Note: Do not use double O-rings or seals. One seal, properly designed is all that is required. The second seal causes virtual leaks.
- Note: Gasket seals are not recommended for a tight leak spec. due to the potential for virtual leaks.
- Seal holders should have positive metal stops that are consistent. Seals should have proper relieves to minimize virtual leaks.
- Sealing material should fit the application. For high wear applications, polyurethane and natural rubber can be considered.
- Expandable seals must be properly designed (see example figure 3). When using commercially available expandable seals that are pneumatically driven, make sure that air leak from the actuating cylinder can not get into the test volume (leaking into the UUT, or vacuum chamber) as this will bias the leak test results! Expandable seals must have means to stop seal “creep” during test. Using the UUT as hard stop is always preferred.
- Fixture design should support the part to prevent expansion during actual leak test. This is applicable to flexible products such as polyethylene packages, etc.
- Minimize fixture volume or add filler for UUT with large cavities in order to minimize test setup volume (see figures 1,2,3). The larger the volume the slower a given leak flow will develop. Filler must be made out of solid machined materials. Casting or molded filler risk porosity and virtual leaks.

Be aware of “virtual leaks” for leak tests with tight leak flow specifications. Virtual Leaks are “hidden cavities” in the part and test fixture, which will take longer times to charge with pressure or to evacuate. It will also take longer times to deplete the pressure at the end of the test. Virtual leaks may look as “leaks” as they consume air to charge them.

Virtual leaks will cause test cycle times to be longer (in order to charge the parts) and require sufficient time between consecutive tests to deplete or recharge the UUT pressure. Insufficient time between consecutive tests will result in poor test repeatability. Design your test fixture and sealing mechanism to minimize virtual leaks!

INTERFACE

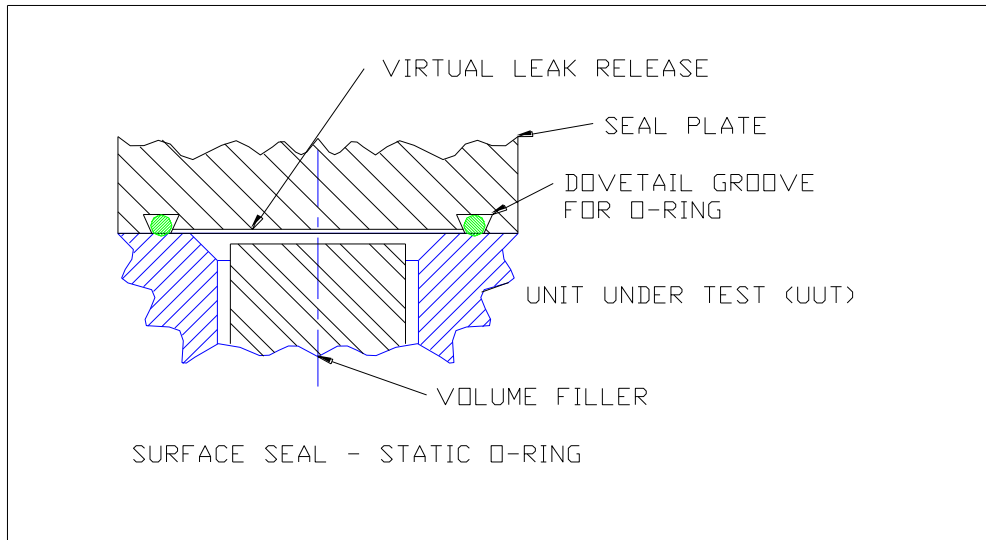

Figure 3.5.1: Surface seal design with static o-ring. Note: top plate contacts the part to provide hard stop and movement during test.

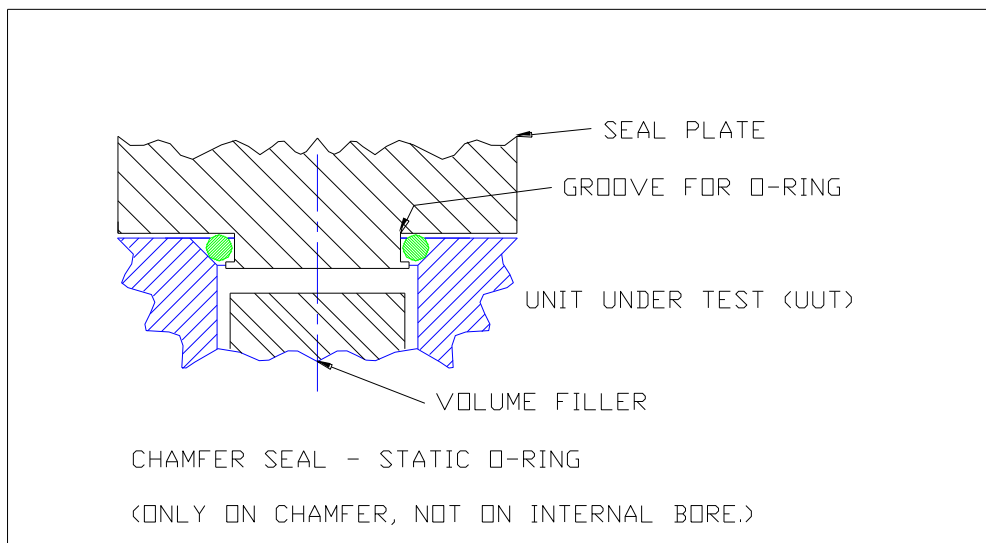

Figure 3.5.2 Chamber seal design using o-ring. Seal plate contacts the part, to provide hard stable stop. (Note: Seal does not seal on the internal bore.)

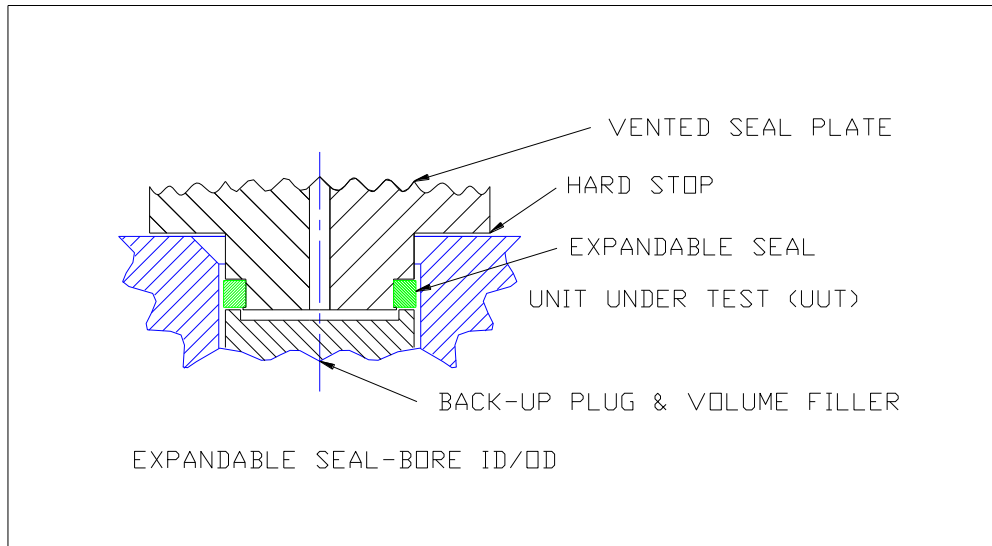

Figure 3.5.3 Expandable seal design – seal expands as seal plate moves downward. Same concept can also be applied to ODs. Seal plate contacts the part to provide stable hard stop.

3.6 Guidelines for setting up Model ME2 Leak Tester

1. Unpack the Model ME2 and make sure the unit is in good condition with the proper caps.
2. Power Model ME2 and check reading. The temperature should read close to ambient and pressure should show >10 torr.
3. Connect mixing tank per schematic.
4. Connect vacuum source and start evacuating unit to test vacuum pressure, allowing time to stabilize. Make sure all the connections are leak free.
5. Run test with the unit capped with the brass cap provided. The reading should be close to “zero.” If high or low flow is observed check all upstream and downstream connections for leaks.
6. Run test with the internal calibrated leak open. The reading should be close to the orifice value as indicated on the tag at the back of the Model ME2.
7. Procure multiple non-leaking parts.
8. Connect PC or Laptop to the Model ME2 serial Port.
9. Open Leak-Tek and go to the set up screen and input the desired pressure setting with +/- 10% on the min/max pressure. Input desired flow unit and Pre-evac, evac stability and test and min/max flow. Make sure the max flow is higher initially and the min flow about -2% of the sensor full scale (ex. for a 10ug/min full scale sensor min flow could be -0.2 ug/min). (**NOTE:** For custom applications more configurations may be necessary. Contact ATC for assistance)

INTERFACE

10. Run test with the good parts and then run the good parts with the internal calibrated leak open.
11. Make sure the difference between the good parts and the simulated bad parts is 2 times or more, adjust the timing accordingly.
12. The max flow criteria should be set at 20% below the average of the simulated bad parts.

3.7 Verification Procedure

A periodic verification is recommended during the normal operation of the Model ME2. Run the test with a known good part and the internal (or external) calibrated leak device engages (valve open). This should fail the test. Run a similar good part without the internal calibrated leak and this should pass the test. If this sequence does not give the desired results, system/parts need to be checked and verified. The procedure will need to be repeated until desired results are obtained.

CAUTION:

A test time should be more than 1 second and the buffer size should be between 5-50. Consult Leak-Tek© program manual on how to set these variables.

3.8 Accessories for Safe Operation

The end use of the ME2 product varies greatly based on the customer's leak testing requirements. There are no standard safe operation accessories offered for the ME2. Please consult ATC to help define any additional safe operation accessories that should be utilized when operating ME2 products based on the testing requirements.

4. IMFS-Model ME2 Operation Sequence

The Model ME2 leak test will run based on the sequence below after the "start" button is pressed on the front panel. Model ME2 Leak Test Sequence- Basic circuit only:

1. If the clamping valve is enabled, energize the clamping valve in order to clamp, or connect a pneumatically driven clamp, or an automatic expander seal.
2. After the clamping time delay, during the pre-evac time the quick evac valve is enabled, the iso valve is enabled, and the UUT is evacuated with the IMFS isolated.
3. After pre-evac time delay, the test valve is opened. The evac valve is enabled and opened to equalized pressure to the UUT.
4. After evacuation valve time delay, the evacuation/balance valve and quick evacuation valve are closed. Stability time begins. Stability time can be as short as 0.025 seconds for Mass Extraction applications. (For ME2 operating at hard vacuum- iso valve open, otherwise-isolation valve closed)
5. After stability time expires, the leak test starts.
6. Test time follows the stability (no valve action between stability and test steps). During test time, the flow and pressure readings are compared to the setup values in the IMFS, and a pass or fail decision is made.

CAUTION:

A test time should be no less than 1 second and the buffer size should be between 5-50.

7. Passing or failing a test:
 - a. If the UUT meets the test criteria within the set test time, the UUT has passed the test. If the test passes, all valves will be de-energized to deplete the pressure from the UUT and to contain the internal pressure. The pass message will be displayed on the LCD, and the green "pass" light will be turned on.
 - b. If the UUT fails the test criteria at any point during the test time, the UUT has failed the test. If the test fails, the failure message will be displayed on the LCD, and the red "fail" light will be turned on.

OPERATION SEQUENCE

- c. Continue re-testing if the "deplete pressure" feature is disabled. ($X_5=0$. See Appendix B command list.) If the "deplete pressure" feature is enabled, de-energize all valves ($X_5=1$. See Appendix B command list).
8. If the "stop" button is pressed at any time during the test process, the test will be stopped with all valves de-energized and the analog output at zero.
9. To switch to the other test type, press the "test select" button or pulse the "remote test select" digital input.

OPERATION SEQUENCE

NOTE:

The second generation IMFS / IGLS allows flexibility in set up the test sequence. The test sequence/steps are set by ATC or only authorized persons. Many applications may have customized valve configurations and test set-ups. For assistance with these features consult Leak-Tek program© manual and contact an ATC, Inc. representative.

OPERATION SEQUENCE

The following cases involve additional test steps:

- Pre-fill or Pre-evac option: test starts with pre-fill/pre-evac, while the leak test circuit and pressure/test and iso valves are closed, exhaust valve is closed. The initial pre-fill/pre-evac step follows a pressure switch test, if pressure/vacuum not reached within the allowed time, the test stops.
- Large Leak Test- Large leak test is for testing for larger leak, enabling the user to test given cavities for larger leaks before continuing to check same or other cavities to a finer leak test. During mass extraction test, for closure integrity testing (part with limited, confined air volume), the large leak test is used to detect larger defects that may deplete all the air from the closure under test.
- Blockage/pressure deplete test- if a pressure switch at the basic test circuit is installed, a step at the end of the test may be added to check if test pressure is depleted within the allowed time (indication of UUT path of flow is not totally blocked).

NOTE:

If a PC is attached to the Model ME2 with “Leak-Tek © program” running the Pass/Fail will be displayed and saved in the Leak-Tek © program run screen. However, the Pass/Fail decision is made by the IGLS.

CAUTION:

During normal operation, if a part failed due to failure mode “Flow saturation” or “Gross Leak”, the isolation tank can get significantly depleted. If this condition happens, the tank should be allowed to recover and get back to its original condition, and no leak test should be run during this recovery period. Repeat verification procedure.

NOTES:

1. When the UUT has a large volume and a small flow IMFS is used, “back flow” due to pressure fluctuations from the UUT, will “mask” leaks. Therefore, set V4 to 0 to “lock” the pressure output if the electronic pressure controller is used. (This option is applicable when running with an external pressure controller.)
2. When a large volume is used with a large flow Model ME2, a slight pressure rise may be experienced after closing the evacuation valve, due to flow consumption and change of flow resistance. To compensate for this phenomenon, set K4 to a negative value, which will cause the pressure controller to aim for a lower pressure during evacuation time. (This option is applicable when running with an external pressure controller.)
3. For high-speed applications, and especially low flow, the Model ME2 is recommended to monitor the change in flow rates. Initially set evacuation and stability time to very long values and record changes in flow vs. time. Define the slope for a good and rejected part. Then set the stability time and maximum flow rate to meet this slope. Use the verification orifice for reference of known leak rate.

OPERATION SEQUENCE

4. For mass extraction method, the leak criteria (V_2) depends on the size of the UUT leak, the size of the chamber if applicable, and the test time.
5. Typically,
 - a. The larger the UUT leak, the larger the leak criteria will be.
 - b. The smaller the chamber, the larger the leak criteria will be.
 - c. The longer the test time, the larger the leak criteria will be.

5. Graphic LCD Display & Touch Screen

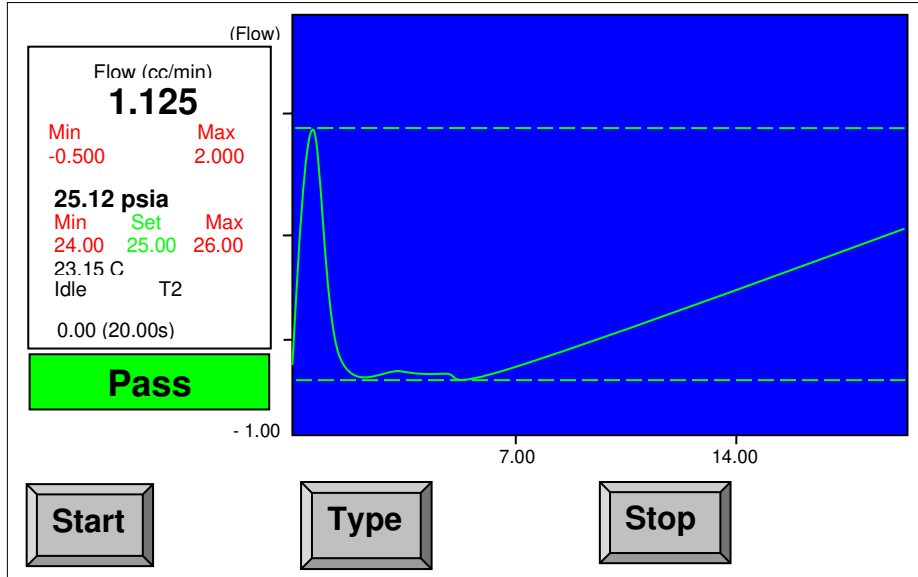

Figure 5.1 - Model ME2 Control Panel

The Model ME2 control panel is shown in Figure 5.1. On the left, the current pressure, temperature and flow readings are displayed in real time as well as the pressure and flow settings. The pressure, temperature, and/or flow, in the user selected engineering units by programming U₃, U₄, and U₅. (See Appendix B for details.)

On the right, a blue background graph displays the flow measurement signature for the entire leak test. The two dotted lines represent the upper and lower limits of the leak test flow tolerance. The solid line is the flow measurement.

At the bottom of the screen, there are three toggle buttons available. The visibility of the buttons can be individually configured. If they are visible, then:

Start: Start a leak test if it is idle

Stop: Stop an ongoing leak test

Type: Switch from one Test Type to the other, increment by one (1) or back to Test Type 1 if it reaches the maximum number of the test types.

On the right side of the status message, it will display T2 if it is in test Type 2 Mode, T3 if in Test Type 3 and T4 if in Test Type 4. The sensor is in Test Type 1 if there is no message like "T2".

The verification switch opens or closes the calibrated leak valve to initiate flow through the calibrated leak.

The following table shows the various messages possible on the LCD.

LCD DISPLAY

Message	Description
Idle	Displays the pressure and flow reading in flow measurement, together with engineering unit in normal condition.
OpenFillPres	Displays the pressure and flow reading with the step status in the process of the test. The IGLS will open the pressure valve and filling valve.
Filling	Displays the pressure and flow reading with the step status in the process of the test. The IGLS is filling gas.
Stab Delay	Displays the pressure and flow reading with the step status in the process of the test. The IGLS is stabilizing the flow for testing.
Testing	Displays the pressure and flow reading with the step status in the process of the test. The IGLS is in test step.
Pass	Displays the pressure and flow reading with pass message after the test passed.
Stop	Displays the pressure and flow reading with stop message, if the test is intentionally stopped manually.
Fail	Displays the pressure and flow reading with failure message if the test fails. The reason for failure is shown on the LCD.
GrossLeak	During test time, pressure is under Pressure Min (K3) setting in pressure testing
GrossLeakV	During test time, pressure exceeds Pressure Max (K2) setting in vacuum testing
No-Pres	Pressure Switch not turned on in time (Version 2.0.0 or later)
OverPres	During test time, pressure exceeds Pressure Max (K2) setting in pressure testing.
UnderPres	During test time, pressure is under Pressure Min setting in vacuum testing
PresSat	Pressure exceeds its full range. Deplete pressure immediately!
FineLeak	During Test, flow is larger than maximum allowed flow (V2), or the accumulated flow during the test period is larger than the allowed leak (V2)
Low Flow	During test, flow is lower than minimum allowed flow (V1).
FlowSat	Flow exceeds maximum sensor flow range.
TempSat	Temperature exceeds maximum limit.
Blockage	Pressure Switch not turned off in deplete time
HiFlow_RM	Relative Measurement –Baseline Flow larger than V6
LoFlow_RM	Relative Measurement –Baseline Flow smaller than V5
LargeLeak	In large leak step, the measured flow is larger than V7
BackFlow	The measured flow in the test step is less than A3
PresRng-Hi	External Pressure higher than set limit (KA)
PresRng-Lo	External Pressure Lower than set limit (K9)
ExtGrossLeak	External Gross Leak Failure (External Pressure Sensor reading Lower than K3) in pressure testing.
ExtOverPres	External Over Pressure Failure (External Pressure sensor reading larger than K2) in pressure testing.

LCD DISPLAY

ExtUnderPres	External Under Pressure Failure (External Pressure sensor reading Lower than K3) in vacuum testing.
ExtGrossLeakV	External Gross Leak Vacuum Failure (External Pressure sensor reading larger than K2) in vacuum testing.

If the valve control sequence is customized, some of the LCD messages displayed might be worded slightly different from the diagram above. However, the messages can be interpreted in a similar fashion.

NOTE:

Starting from version 02.02.01, once the UUT failure is found, it will not be overwritten by the next failure if multiple failures occurred in the same UUT. For example, if both fine leak and blockage failures were found in the test. It will report fine leak failure because it was found first.

The detailed explanations of the graphical LCD are as follows:

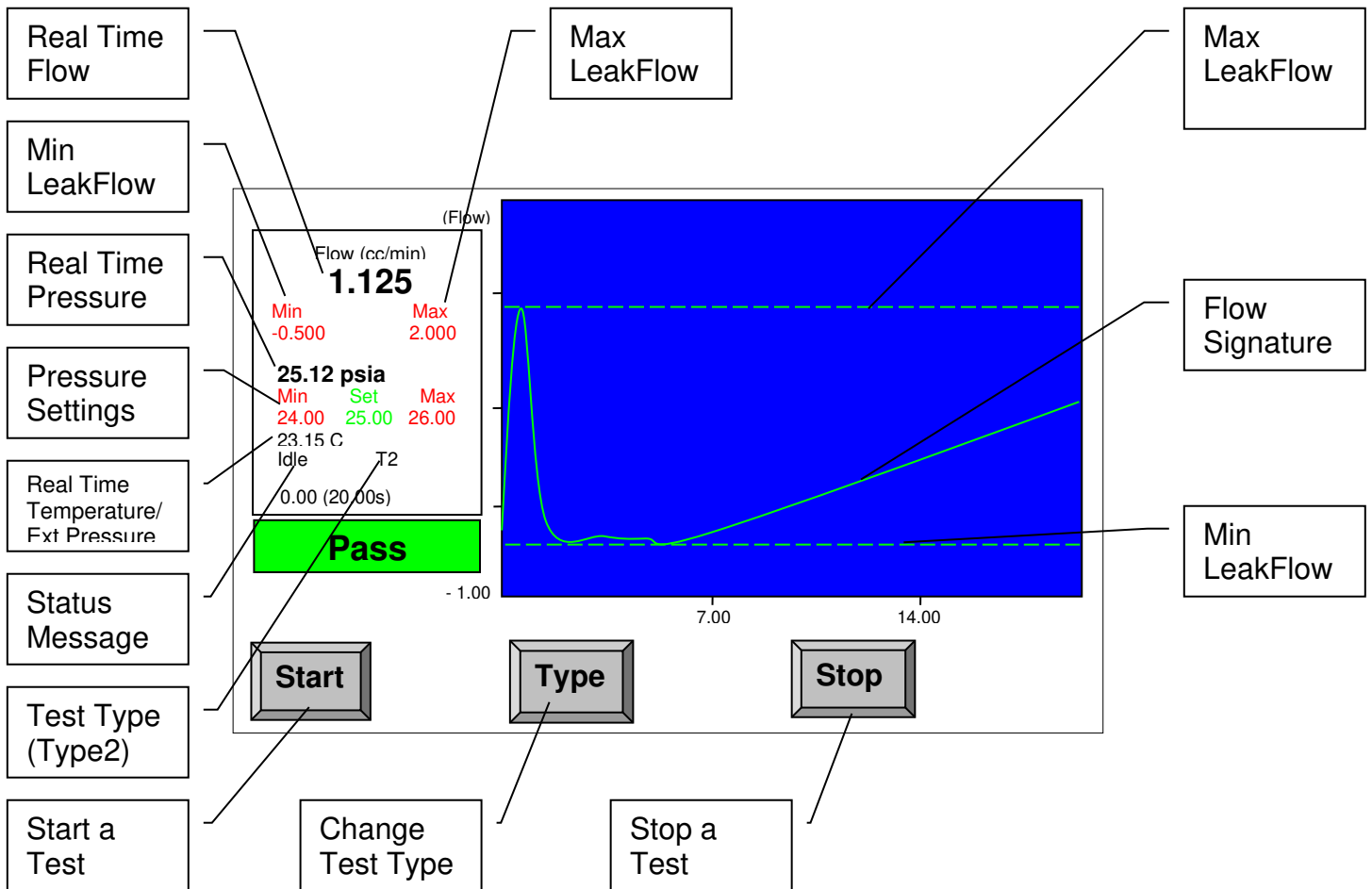

Figure 5.2 - Model "ME2" LCD Element

CONTROL PANEL

The Real Time Pressure and Pressure Settings can be used to display the internal pressure or external pressure sensor(if used in the system) reading. The user can configure it through the Leak-Tek serial software provided by ATC.

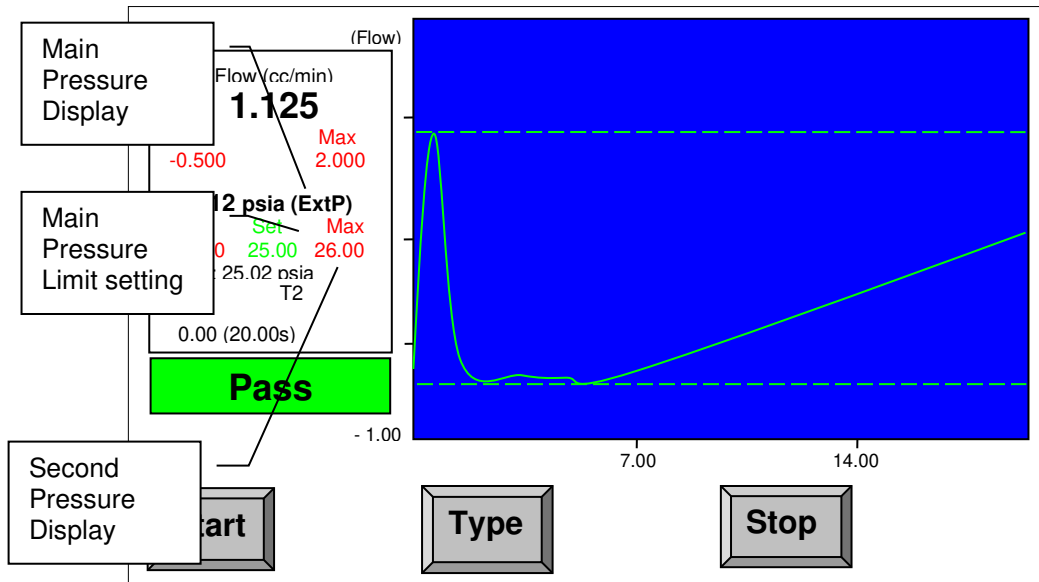

Figure 5.3 - LCD Display with External Pressure sensor replacing Internal Pressure sensor display.

After firmware 2.3.11, the configuration of External and Internal pressure sensor reading display is available from Leak-Tek(version 6.06 or later). The user can choose the either internal or external pressure reading on the main pressure display and the other on the second pressure display, as Figure 5.3 shows. When the external pressure is configured to be displayed in Main Pressure Display, the “ExtP” will follow the pressure unit to imply the pressure reading is external pressure. In the second pressure display, the capital “IntP” or “ExtP” is used to imply internal or external pressure reading is displayed. The second pressure display can also be hidden if user prefers or no external pressure sensor is used. The Main pressure limit setting is used to display the Min and Max limit of the pressure set as main pressure display. Please refers the Leak-Tek manual, section 9.2.3 (version 6.06 or later) to know how to configure the pressure display.

Note: The internal pressure sensor is normally an absolute pressure sensor use for measurements and units conversions (from volume flow to mass flow). The external pressure sensor can be a gage or an absolute pressure sensor. At low test pressure (under +/- 3 psi) the external pressure sensor, if a gage sensor, will not change due to barometric pressure changes. Both sensors must have same pressure measurement units.

6. Communication Protocol

NOTE:

All commands and responses should be terminated by <lf><cr>

6.1 Conventional Commands for Sensor Parameters

Read Command Format:

“!0” + ADDRESS + ”R” + COMMAND

Response Format:

“\$0”+ ADDRESS +”R” + COMMAND; DATA

Save Command Format:

“!0” + ADDRESS + ”S” + COMMAND; DATA

Response Format:

“\$0”+ ADDRESS + ”S” + COMMAND; DATA

where

ADDRESS is valid from 0 to 9. (The first sensor will be respond to 0)

DATA is the number to be saved or read.

COMMAND, see Appendix B.

For example, to change G1 to the 287(Air) in IGLS addressed as 2, the command string will be as follows

```
!02SG1;287.0<lf><cr>
```

Note:

For commands such as U2, U3, U4, U5, the returned DATA are in Hex format of “oxFFFFFFF” in version 2.0.0 or later, however, the data in the command ill be treated as a decimal value unless there is a prefix “0x”. For example, either of the following command will change IGLS addressed as 1 to flow unit mg/min.

```
!01SU5;91 <lf><cr>
```

```
!01SU5;0x51<lf><cr>
```

6.2 DAQ Commands

DAQ string response is in the form of \$01SQ1;Data1;Data2;Data3;StepNo

Where

Data1: temperature reading

Data2: pressure reading

Data3: flow reading

Step No: The step no. will be interpreted as a Hex value, especially if the sensor is configured to run more than 9 steps. For more details, see Section 6.3.

Communication PROTOCOL

For Firmware 2.3.4 or greater, the DAQ string response is in the form of !01SQ5;
Data1;Data2;Data3;Data4;Data5;StepNo

Where

Data1: temperature reading

Data2: pressure reading

Data3: flow reading

Data4: external pressure reading

Data5: adaptive test flow reading

StepNo: The step no will be interpreted as Hex value, especially if the sensor is configured to run more than 9 steps. For detail, see Section 6.3.

SQ1;1	<p>Command: !01SQ1;1 Response: \$01SQ1;Data1;Data2;Data3;StepNo Engineering Value and Step where if (X6<>0) then Data1 refers to temperature in Degree C Data2 refers to pressure in kPa Data3 refers to flow in cc/min or $\mu\text{g}/\text{min}$ Otherwise Data1 refers to temperature in the selected temperature unit. Data2 refers to pressure in the selected pressure unit. Data3 refers to flow in the selected flow unit.</p>
SQ1;2	<p>Command: !01SQ1;2 Response: \$01SQ2;Data1;Data2;Data3;StepNo Average Count Value and Step Data1 refers to temperature in digital count. Data2 refers to pressure in digital count. Data3 refers to flow in digital count.</p>
SQ1;3	<p>Command: !01SQ1;3 Response: \$01SQ3;Data1;Data2;Data3;StepNo Engineering Base Unit Value and Step Data1 refers to temperature in Degree C Data2 refers to pressure in kPa. Data3 refers to flow in cc/ or $\mu\text{g}/\text{min}$</p>
SQ1;4	<p>Command: !01SQ1;4 Response: \$01SQ4;Data1;Data2;Data3;StepNo Engineering Display Unit Value and Step Data1 refers to temperature in the selected temperature unit. Data2 refers to pressure in the selected pressure unit. Data3 refers to flow in the selected flow unit.</p>
SQ1;5	<p>Command: !01SQ1;5 Response: \$01SQ5;Data1;Data2;Data3;Data4;Data5;StepNo</p>

Communication PROTOCOL

	<p>Data1 refers to temperature in Degree C Data2 refers to pressure in kPa Data3 refers to flow in cc/min or $\mu\text{g}/\text{min}$ Data4 refers to external pressure (4th analog input) in kPa Data5 refers to Adaptive flow in cc/min or $\mu\text{g}/\text{min}$</p>
SQ1;6	<p>Command: !01SQ1;6 Response: \$01SQ6;Data1;Data2;Data3;Data4;Data5;StepNo Data1 refers to temperature in digital count. Data2 refers to pressure in digital count. Data3 refers to flow in digital count. Date4 refers to external pressure (4th analog input) in digital count</p>
SQ1;7	<p>Command: !01SQ1;7 Response: \$01SQ7;Data1;Data2;Data3;Data4;Data5;StepNo Engineering Base Unit Value and Step Data1 refers to temperature in Degree C. Data2 refers to pressure in kPa. Data3 refers to flow in cc/min or $\mu\text{g}/\text{min}$. Date4 refers to external pressure (4th analog input) in kPa Data5 refers to adaptive flow in cc/min or $\mu\text{g}/\text{min}$</p>
SQ1;8	<p>Command: !01SQ1;8 Response: \$01SQ8;Data1;Data2;Data3;Data4;Data5;StepNo Engineering Display Unit Value and Step Data1 refers to temperature in selected temperature unit Data2 refers to pressure in selected pressure unit Data3 refers to flow in selected flow unit Date4 refers to external pressure (4th analog input) in selected pressure unit Data5 refers to adaptive flow in selected flow unit</p>
SQ1;9	<p>Command: !01SQ1;9 Response: \$01SQ9;Data1;Data2;Data3;StepNo;TimeStamp Engineering Value and Step where if (X6<>0) then Data1 refers to temperature in Degree C Data2 refers to pressure in kPa Data3 refers to flow in cc/min or $\mu\text{g}/\text{min}$ Otherwise Data1 refers to temperature in the selected temperature unit. Data2 refers to pressure in the selected pressure unit. Data3 refers to flow in the selected flow unit.</p>
SQ1;A	<p>Command: !01SQ1;A Response: \$01SQA;Data1;Data2;Data3;Data4;Data5;StepNo;TimeStamp Data1 refers to temperature in Degree C</p>

	<p>Data2 refers to pressure in kPa Data3 refers to flow in cc/min or $\mu\text{g}/\text{min}$ Data4 refers to external pressure (4th analog input) in kPa Data5 refers to Adaptive flow in cc/min or $\mu\text{g}/\text{min}$</p>
SQ1;B	<p>Command: !01SQ1;B Response: \$01SQB;Data1;Data2;Data3;Data4;Data5;StepNo;TimeStamp Engineering Display Unit Value and Step Data1 refers to temperature in selected temperature unit Data2 refers to pressure in selected pressure unit Data3 refers to flow in selected flow unit Date4 refers to external pressure (4th analog input) in selected pressure unit Data5 refers to adaptive flow in selected flow unit</p>
SQ2;1	<p>Command: !01SQ2;1 Response: \$01SQ2;1 Auto Zero to update C1</p>
SQ2;2	<p>Command: !01SQ2;2 Response: \$01SQ2;2 Auto Zero to update C5</p>
SQ2;3	<p>Command: !01SQ2;3 Response: \$01SQ2;3 Auto Zero to update C1 and C5</p>
SQ3;1 or 0	<p>Command: !01SQ3;0 to Set the Parameter to Type 1 Command: !01SQ3;1 to Set the Parameter to Type 2 Command: !01SQ3;2 to Set the Parameter to Type 3 Command: !01SQ3;3 to Set the Parameter to Type 4 Response: Don't care the response</p> <p>Note: After the command is sent, all following commands related to T, V, and K groups are corresponding to that test type regardless what the current test type is.</p>
RQ3	<p>Command: !01RQ3 Response: \$01RQ3;0: Currently in Test Type 1 Response: \$01RQ3;1: Currently in Test Type 2 Response: \$01RQ3;2: Currently in Test Type 3 Response: \$01RQ3;3: Currently in Test Type 4</p> <p>Note: This command only returns with the which test type currently active, which is decided by the test type toggle switch digital input to the sensor, independent of SQ3 command result.</p>

NOTE:

For all SQ1 commands, the sensor will respond with two strings with the first string similar to \$00SQ1;1, DAQ string as the second one if U6<>0. Otherwise, it will respond with the DAQ string only.

If the sensor is configured as mass extraction mode, Data1 carries the accumulated mass or volume instead of temperature during the test step.

SQ1;1 Command ONLY

When the mass extraction method is used, Data1 will refer to the temperature in °C or in the selected temperature unit in all sensor steps except in the test step. In the test step, Data1 represents the real-time accumulated leak in the selected mass or volume unit.

For example, mg if mg/min is selected as flow unit.
Liter if liter/hr is selected as flow unit.

If the sensor is configured as an adaptive leak tester, Data1 carries the predicted flow instead of temperature during the test step.

SQ1;1 Command ONLY

When the sensor is configured as adaptive leak tester, Data1 will refer to the temperature in degree C or in the selected temperature unit in all sensor steps except in the test step. In the test step, Data1 represents the real-time calculated leak in the selected mass or volume unit.

Before the firmware 2.3.14, the length limit of the response message is **55** characters. For Firmware 2.3.14 and greater, the limit of the message length is **75** characters

6.3 Step Number

Typical Step Number Table (Hex System)

Step	Built-in Sequence	Customized Sequence/Description
0,100	Standby	Standby
1	Open Clamping Valve	Customized
2	Open Pressure and Fill Valve	Customized
3	Filling	Customized
4	Stability	Customized
5	Test	Customized
6,7	Close all valves	Customized
8	Stop	Customized
9	Customized	Customized
A		Customized
B		Customized
C		Customized
D		Customized
E		Customized
F		Stop*
16	Pass	Pass
17	Pass-RM	Pass – Relative Measurement
18	Pass-RF	Pass – Reference Flow Measurement (The reference flow test must be enabled and activated in the current test type. Please refer the Leak-Tek manual (version 6.06 or later) section 6.3.3 and 5.3.3.1).
21	PresSat	Pressure Sensor Saturated Failure
22	FlowSat	Flow Sensor Saturated Failure
23	TempSat	Temperature Sensor Saturated Failure
24	GrossLeak	Gross Leak Failure (Pressure Lower than K3)in pressure testing
25	FineLeak	Fine Leak Failure (Flow larger than V2)
26	Low Flow	Low Flow Failure (Flow Lower than V1)
27	OverPres	Over Pressure Failure (Pressure larger than K2) in pressure testing
28	BackFlow	Backflow Failure (Flow sensor smaller than A3)
29	Blockage	Blockage Failure –Pressure Switch not turn off in deplete time (T6)
2A	No-Pres	No Pressure Failure (Pressure Switch not turned on in time)

Communication PROTOCOL

2B	HiFlow_RM	Relative Measurement Baseline Flow Too High
2C	LoFlow_RM	Relative Measurement Baseline Flow Too Low
2D	LargeLeak	Large Leak Check Failure (Flow larger than V7 at Large Leak check Step)
2E	UnderPres	Under Pressure Failure (Pressure Lower than K3) in vacuum testing
2F	GrossLeakV	Gross Leak Vacuum Failure (Pressure larger than K2) in vacuum testing
30	PresRng-Hi	External Pressure higher than set limit (KA)
31	PresRng-Lo	External Pressure Lower than set limit (K9)
32	ExtGrossLeak	External Gross Leak Failure (External Pressure Sensor reading Lower than K3)in pressure testing.
33	ExtOverPres	External Over Pressure Failure (External Pressure sensor reading larger than K2) in pressure testing.
34	ExtUnderPres	External Under Pressure Failure (External Pressure sensor reading Lower than K3) in vacuum testing.
35	ExtGrossLeakV	External Gross Leak Vacuum Failure (External Pressure sensor reading larger than K2) in vacuum testing.

Figure 6.1 - Step Number Interpretation

The Step number in DAQ response string shall be interpreted as a Hex Value although there is no hex prefix such as "0x". Any step numbers between 1 to E could be valid step numbers depending on the customized valve sequence. For example, the sensor is configured to have 12 steps in the test. The customized step number shall be C (12) steps. D (13) will be reported in the DAQ response string of the stop step if the user pushes the stop button during the test. Step numbers between 10 and 100 shall be interpreted exactly the same among all sensor versions and all different configurations.

7. Maintenance and Troubleshooting

7.1 Periodic Maintenance and Calibration

WARNING:

Only qualified and trained professionals should operate and maintain the Leak Test Instrument, Model ME2.

WARNING:

The internal calibrated leak is an integral part of the Model ME2. Under no circumstances should it be opened or tampered with.

WARNING:

The Model ME2 contains vacuum. Make sure to deplete internal vacuum before beginning any maintenance work that requires opening any internal components.

WARNING:

The Model ME2 contains AC lines, power supply and valves. Disconnect the power cord from the power outlet before opening the model ME2 rear door and during any electrical work.

WARNING:

The Model ME2 should only be serviced by trained and authorized personnel. If for any reason the Model ME2 needs to be opened for troubleshooting or service call ATC for authorization before opening.

7.1.1 Filter

The IMFS Model ME2 is provided with an in-line filter. The filter is at the inlet of the IMFS. Periodically clean or replace the filter, as necessary. The exhaust valve (sometimes installed on the outside the leak test instrument) is supplied with an in-line filter. The filter must be periodically checked, replaced or cleaned. With Model ME, for vacuum applications, a filter is typically installed at the test port. Periodically check, clean, or replace this filter.

7.1.2 Periodic Calibration

The IGLS in the Model ME2 is a measuring device. Periodic calibration, typically annually, by authorized personnel and standards is required. Refer to the Leak-Tek or GAS-CAL manuals for the instrument calibration procedures.

7.1.3 System performance Verification

The IGLS and Model ME2 can be supplied with internal calibrated leak (optional), or equivalent channel standards (optional) that are calibrated at a certain pressure and flow. A valve isolates the orifice. This valve can be turned on and off by the calibration switch provided in the front panel. The verification orifice should not be used for instrument calibration, but system performance verification and diagnostic of a component failure (such as valves or a system leak). Follow the following procedure to verify the Model ME2 performance:

1. Set the system pressure and allow it to stabilize.
2. Open the calibration valve and allow the flow to stabilize.
3. Record the IMFS readings and compare them to orifice flow calibration at that pressure.

NOTE:

When comparing to equivalent channel (EC) standard calibration data, compensation must be performed for different gases, pressure and temperature compared to the value recorded on the EC laminated tag, attached to the EC/verification orifice.

With a new, proven unit and system, (FIRST TIME AFTER INSTALLATION) set up one test and make sample tests (same test parameters). Establish the system verification flow tolerance. Recommended tolerance is +/- 3 times the standard deviation of the initial sample.

Periodic readings should be taken at the same test setup and compared to the flow verification tolerance. If readings (at same pressure range) are higher, after a few tests, look for a leak downstream from the IGLS. If the readings are too low, look for a leaking evacuation valves, upstream leak or clogged inlet filter or lines. In each case, the cause of the problem (readings out of the verification tolerance) must be resolved prior to test continuation.

MAINTENANCE AND TROUBLESHOOTING

7.2 Troubleshooting

The following table summarizes some common problems that may occur, and repair recommendations.

No.	Description	Possible Cause	Repair Action
1	LCD doesn't light	Power supply 5 VDC not available Bad LCD or internal component	Check power supply Check D connector Measure 5 VDC and common Consult ATC
2	LCD Only Displays Partial Screen	The LCD momentarily lost power	Turn off and turn on the power supply. Click the two buttons Deactivate and Activate in the LeakTek Run Screen.
3	No communication with PC and data saving	Communication problem	Check 9-pin RS232 cable between Model ME2 and PC Check PC COM port settings Check Model ME2 address Power down the unit, wait 2 minutes before power up
4	Test will not start	Damaged wiring Bad control panel component	Check for damage to internal wiring Consult ATC
5	"?" Symbol near the test status (e.g "idle")	Pressure is too high for this operating /calibration flow regime	Check vacuum pump Compare pressure setting in "torr" to the A4 value from maintenance screen. A4 should be larger than your pressure setting.
6	Test fails with message UnderPress (typically after "Pre-Evacuation step")	Pressure is under the Minimum Pressure setting	Check that vacuum controller and mixing valve operating, especially that bleed orifice (between the mixing tank and vac. Pump) or its filter are not clogged. Check your set up with LeakTek program.

MAINTENANCE AND TROUBLESHOOTING

7	Test fails with message Gross Leak (typically after “Pre- Evacuation step”)	Pressure is over the maximum allowed pressure	Check for gross leak, missing UUT that do not allow vacuum level to be reached at the given test time. Check if you have vacuum switch- that it sets/operates properly. Check your set up of max. pressure or pre-evac. Time using LeakTek program ©
8	Valves not working	Damaged wiring Bad valves Bad control panel components	Check for damage to internal wiring Check valves; Consult ATC for replacement parts Consult ATC
9	Automatic Pressure/Vacu um controller does not get to zero, no control	No analog voltage output 12 VDC not available Defective pressure control	Check analog output voltage on rear panel connector Check for damage to internal wiring Power down the unit, wait 2 minutes before power up; Analog voltage output should be 0. If not, consult ATC. Check 12 VDC supply Check for defective pressure/flow controller

MAINTENANCE AND TROUBLESHOOTING

No.	Description	Possible Cause	Repair Action
10	Pressure Sensor readings are incorrect	Measurement units are not set properly Pressure sensor has large offset-sensor was over pressurized. Pressure sensor calibration coefficients corrupted Loose connection No power supply	Verify measurement units using Leak-Tek © program. Check pressure sensor calibration and verify proper calibration coefficients. Check for 12 VDC power supply In case of large reading offset, typically pressure sensor was over-pressurized. Contact ATC.
11	IMFS shift of flow	Wrong units of meas. Temperature variation IMFS tilted	Check set up and units. Check that sensor installed in a flat/horizontal position. Go to cal. screen and check A/D counts of Flow sensor. Tilt sensor to see if "zero" returns. Perform auto zero but only after consulting with ATC and if A/D counts are less than 200 counts for first Gen IMFS or 3000 for second Gen IMFS Consult ATC
12	IMFS flow reading High all the time, and between tests	Leakage downstream to the IMFS Evac valve not opening Pressure valve leakage IMFS zero shift or unit has moved	Isolate IMFS by plugging the UUT outlet, check downstream fittings and tubing to the IMFS. Check/replace press, calibration and exhaust valve. Check / replace evac valve If high readings persist, plug the IMFS outlet, check A/D counts and compare to original calibration. Auto zero the sensor if A/D counts are under 200.
13	IMFS flow reading too low or very negative (A/D counts is "0").	Leakage through the evac line Leaking evac valve External leakage through the expansion tank or isolation valve. Unstable supply pressure-pressure drops down. Unit clogged	Check/replace inlet filter Check supply pressure Isolate and check evac/by-pass lines Check leakage through evac valve. Check for expansion tank or isolation valve leak. Verify calibration coefficients Check for leaks at the IMFS

MAINTENANCE AND TROUBLESHOOTING

			<p>outlet plugs and fittings Consult ATC for internal cleaning instructions. DO NOT AUTOZERO the flow sensor if flow or any A/D counts are "0"</p>
14	IMFS Flow, pressure and temperature readings do not make sense	Calibration scrambled Power supply damaged	<p>Verify power supply outputs Verify calibration data with original cal. sheet. Check/increase buffer size Check that unit reacts normally (pressure flow readings vary with flow) Recalibrate the unit</p>
15	Cannot pass verification test with the calibrated leak	Upstream leak to leak tester Bad Pressure regulator Equivalent Channel, or calibrated leak are plugged. Leaking evac valve Isolation valve is not closing during stability and test time IGLS measurement is incorrect.	<p>Check for upstream and expansion tank connections. Replace pressure regulator. Plug the leak tester output and repeat the test. Externally connect another Equivalent Channel (Calibrated Leak) to verify that internal calibrated leak is not plugged. If plugged- replace internal Equivalent Channel. See line (4) Consult ATC to replace defective valves. See lines 8,9,10.</p>
16	Test Starts/stops by itself when connected to a remote PLC or PC control system	Current leakage into the opto-isolated inputs of the IGLS	<p>Verify that start and stop signals are through dry contact relay. Install one if missing!</p>
17	IGLS Pressure or Flow readings unstable	Incorrect remote I/O connections. Unstable Power Supply Bad connection Upstream pressure fluctuation cannot be damped enough by the expansion tank	<p>Disconnect I/O connector, to isolate for test machine possible common-ground problems. Check power supply Check Model ME2 or IGLS connections. Check internal IGLS connection Check upstream pressure, increase expansion tank size and add an isolation valve if</p>

MAINTENANCE AND TROUBLESHOOTING

			required.
18	Inconsistent test performance – many parts fails, although verification passes	Pressure supply or pressure regulator is un-stable	Use Leak-Tek and monitor test pressure at end of test of consecutive test. Pressure should be stable within few hundreds of a psi for consecutive tests. If not, check the supply line, additional buffer tank may be required, check for “cross talk” between adjacent pressure regulators, check/replace the pressure regulator.
19	Low flow or Backflow failures	Improper test set up clamp/seals are moving during test, external leak into test cavity, or part volume is not stable during test	<p>Low flow failure is a result of airflow from the unit under test into the expansion tank (back-flow) lower than min. allowed flow.</p> <p>A factory built in backflow safeguard for back flow (redundant to the min flow) will prevent the user to set up min. flow too low. If flow is under this value a “backflow failure” will occur.</p> <p>Re-verify that there is no upstream leak. Check for eternal leak into test cavity (e.g. from air actuated expandable seals). Make sure that part is stable and seals are not compressed during leak test, and volume does not “shrink” during the stability and test time. Allow for proper seal stops and part support to overcome such cases. Check your test set up and allow (for troubleshooting purpose) longer evac and stability time. Run test with Leak-Tek and monitor the signature.</p>

MAINTENANCE AND TROUBLESHOOTING

20	LCD screen is distorted	Power Spike or rough handling of the instrument may cause the LCD	Touch the right-hand side of the LCD screen to refresh the screen.
----	-------------------------	---	--

Figure 7.2.1 - Troubleshooting

Appendix A - Calculation Algorithm

1. Density Calculation

$$D = \frac{P+Q*V_3}{G_1*(T+273.15)}$$

where

D Density of the gas in mg/cc

R Constant of the gas (For example, Air = 287)

T Temperature of the gas in degree C

Q Flow Measurement in cc/min.

V₃ Flow compensated Pressure Coefficient (See Appendix B)

Z Gas Compressibility coefficients.

2. Flow Measurement

2.1 Volume Flow measurement for Continuum and slip flow regimes

The volumetric flow calculation is based on the polynomial coefficient and the Capacitance measurement. The IGLS or IGFS measure Volumetric Flow as follows

$$Q = (C_1 + C_2x + C_3x^2 + C_4x^3)(1 + B_4T + B_3T^2)(1 + H_4P + H_3P^2)$$

2.2 Mass Flow measurement for the transitional and molecular flow regime

$$dM / dt = (C_1 + C_2x + C_3x^2 + C_4x^3)$$

where

x is the count reading from the Capacitance Sensor.

Q is volume flow measurement in cc/min (mL/min).

dM/dt is the mass flow in μ g/cc (micro-gram/cc)

C₁, C₂, C₃, C₄ are Flow Coefficients. (See Appendix B)

B₃, B₄ are Temperature/Viscosity Compensation Flow Coefficients. (See Appendix B, default is "0")

H₃, H₄ are Pressure Compensation Flow Coefficients. (See Appendix B, default is "0")

T is temperature in Degree C.

P is pressure in kPa.

3. Mass Flow to Volume flow conversion

The mass flow calculation is based on the following formula:

$$dM / dt = Q * \rho$$

And

$$Q = \frac{dM / dt}{\rho}$$

where

dM/dt is the mass flow in μ g/cc (micro-gramm/cc)

Q is the volumetric flow in cc/min.

ρ is the density in μ g/cc.

3.a Mass Extracted:

$$M = \int_{t_0}^{t_{test}} \frac{dM}{dt} \cdot dt$$

Where

dM/dt is the mass flow in mg/cc

t_0 : The starting time of the test step.

T_{test} : The ending time of the test step.

4. Temperature Calculation

$$T = B_2 + B_1x$$

where

x is the count reading from the temperature sensor.

T is temperature in Degree C.

B_1 , B_2 is Temperature Coefficients. (See Appendix B)

5. Pressure Calculation

$$P = H_2 + H_1x$$

where

x is the count reading from the pressure sensor.

P is pressure in kPa.

H_1 , H_2 is Pressure Coefficients. (See Appendix B)

APPENDIX B - Command List

Notes:

1. All calibration coefficients are in the unit of °C, flow base unit or kPa if applicable.
2. Density is in the unit of mg/cc.
3. Time is in the unit of 10 ms.
4. All configuration coefficients are in the selected flow unit or kPa if applicable, except for item 5.
5. If X6 is set to 0,
 RS232 data acquisition response is in the selected unit.
 If X6 is set to other than 0,
 RS232 data acquisition response is in the °C, base flow unit or kPa.

B.1 A Group

Command	Type	Note
A1	float	Analog Output Full scale corresponding flow in selected flow unit.
A2	float	D/A calibration, Count/kPa
A3	float	BackFlow if count reading in DP is less than A3
A4	float	Barometric condition of the pressure in kPa
A5	float	Min Pressure for Volume Flow sensor or Max Pressure For Mass Flow Sensor

B.2 B Group

Command	Type	Note
B1	float	Temperature Calibration Slope(C/Count)
B2	float	Temperature Calibration Offset(C)
B3	float	Temperature Compensation Flow Coef (2nd order)
B4	float	Temperature Compensation Flow Coef (Linear)
B5	float	Calibrated Temperature in Deg. C

B.3 C-Group

Command	Type	Note
C1	float	Offset Flow Coef(cc/min or $\mu\text{g}/\text{min}$)
C2	float	First-order Flow Coef(cc/min/count or $\mu\text{g}/\text{min}/\text{count}$)
C3	float	Second-order Flow Coef(cc/min/count ² or $\mu\text{g}/\text{min}/\text{count}^2$)
C4	float	Third-order Flow Coef(cc/min/count ³ count ² or $\mu\text{g}/\text{min}/\text{count}^2$)
C5	float	Lo Offset Flow Coef(cc/min or $\mu\text{g}/\text{min}$)
C6	float	Lo First-order Flow Coef(cc/min/count or $\mu\text{g}/\text{min}/\text{count}$)
C7	float	Lo Second-order Flow Coef(cc/min/count ² or $\mu\text{g}/\text{min}/\text{count}^2$)
C8	float	Lo Third-order Flow Coef(cc/min/count ³ or $\mu\text{g}/\text{min}/\text{count}^3$)
C9	float	Percent Divider % (such as 10)
CA	float	Smooth % (such as 1)
CB	float	Calibrated Gas Constant
CC	float	Calibrated Gas Viscosity

B.4 D Group

For Adaptive flow test:

Command	Type	Note
D1	float	Buffer Time in % of the test period
D2	float	Safety Multiplier = 2 to 6
D3	float	Test Start Leak Window Max in multiplier of V2 (1.2)
D4	float	Test Start Leak Window Min in multiplier of V2 (0.8)
D5	float	Alpha (Curve) (0-1)

B.5 G Group

Command	Type	Note
G1	float	Universal Constant of the Gas (287 for air): Necessary if density is used in calculation.
G2	float	Viscosity at 0 °C
G3	float	Viscosity change per °C.
G4	float	Density of the gas at standard barometric condition in mg/cc, used for standard flow unit such as SCCM etc
G5	Float	Sensor Alpha (kPa/(cc/min)). $G5=(DP \text{ range})/(\text{Sensor full scale}) * 0.24884$

APPENDIX B – COMMAND LIST

B.6 H Group

Command	Type	Note
H1	float	Pressure Calibration Slope(kPa/count)
H2	float	Pressure Calibration Offset(kPa)
H3	float	Pressure Compensation Flow Coef (2nd order)
H4	float	Pressure Compensation Flow Coef (Linear)
H5	float	Calibrated Pressure in kPa
H6	float	Pressure Calibration Slope (kPa/Count)
H7	float	Pressure Calibration Offset (kpa)

B.7 K Group

Command	Type	Note
K1	float	Pressure Setting for Leak Test mode (kPa)
K2	float	Pressure Upper Limit(kPa)
K3	float	Pressure Lower Limit(kPa)
K5	float	Pressure Setting for Leak Test mode (kPa) for large leak check with dual pressure settings
K6	float	Pressure Upper Limit(kPa) for large leak check with dual pressure settings
K7	float	Pressure Lower Limit(kPa) for large leak check with dual pressure settings
K9	float	Pressure Lower Limit (kPa) for external pressure switch
KA	float	Pressure Higher Limit (kPa) for external pressure switch

B.8 L Group

Command	Type	Phase Label
L1...LE	String	Up to 15 characters per Label

B.9 M Group

Command	Type	Phase Valve Configuration
M1	long	This is not saved in the memory. M1;1 to Calibrate the LCD M1;2 to Activate the LCD M1;3 to Deactivate the LCD M1;6 to change the test type M1;8 to start test M1;9 to stop test
ME2	long	Pass Sound Period (x 10ms), Set 0 to disable
M3	long	Fail Sound Period (x 10ms), Set 0 to disable
M4	long	Stop Sound Period (x 10ms), Set 0 to disable
M5	long	Automatically Deactivate to Screen Saver The timer setting after Idle Condition (x 10ms), Set 0 to disable
M6	long	The setting is based on the combination of the following setting Display/Hide the second pressure 0x400; Switch the internal Pressure and External Pressure 0x200 Alternative Location 0x100; Temperature Reading 0x08; Enable remote command start/stop 0x20; 0:Disable, 1:Enable Enable DIO start/stop 0x10; 0:Enable, 1:Disable Start Button 0x04 Type Button 0x02 Stop Button 0x01
M7	Long	Brightness (1-255)

B10 O Group

Command	Type	Phase Valve Configuration
O1...OE	Integer	The last byte will be configured as follows: Clamp 0x80 Pres/Test 40 Exhaust 0x20 Evac/Balance 0x10 QuickEvac 0x08 Isolate 0x04 Customer1 0x02 Customer2 0x01

APPENDIX B – COMMAND LIST

B.11 P Group

Command	Type	Note
P1	float	PID Proportional Coef
P2	float	PID Integral Coef
P3	float	PID Differential Coef
P4	float	Flow Setting for flow control mode in selected flow unit.

B.12 S Group

Command	Type	Note
S1	String	Serial Number: Up to 14 characters are allowed to enter. For example: <u>XX XX XXX XXX X XXX</u> 1 2 3 4 5 6 1 = Release of month, i.e. 06 = June 2 = Release of year, i.e. 98 = 1998 3 = Serial No. – valid from 001 to 999 4 = Maximum Flow, i.e. 090=90, 120=120, 12H=1,200, 12K=12,000 5 = Flow Unit- C = CCM, L = LPM, U=ug/min, M=mm ³ /min 6 = Maximum Pressure in psia, i.e. 500=500 psia, 12H=1,200 psia, 12K=12,000 psia
S2	String	Read Only Return Version Number such as 020000 for version 2.0.0

B.13 T Group

Command	Type	Built-in Timers	Customized Timers
T1	Integer	Evacuating delay time in 10 ms	Step timer in 10ms
T2	Integer	Stability delay time in 10 ms	Ditto
T3	Integer	Test time in 10 ms	Ditto
T4	Integer	Clamping delay time in 10 ms	Ditto
T5	Integer	N/A	Ditto
T6	Integer	N/A	Ditto
T7	Integer	N/A	Ditto
T8-TE	Integer	N/A	Ditto

Note: All T group settings are defined as long integer (32 Bit) since Ver 2.1.3.

B.14 U-Group

Command	Type	Note
U1	Integer	Address 1-9
U2	Integer	<p>Mode: 4th Byte</p> <p>Sensor Type Conventional Leak Tester 0 Adaptive Leak Tester 1 Flow Controller 2 Mass Extraction Method 3 Steady state Predictor 4</p> <p>3rd Byte 0x0 0 <u>1</u> <u>1</u> 0 0 <u>1</u> <u>1</u> Bit 0: When '1', Sensor is configured as Model XE Bit 1: Reference Flow function</p> <p>Bit 2: Quick Reference Flow function Bit 4: When '1', Sensor is configured for 4th analog input Bit5: PID Pressure sensor selection, 0=Internal Pressure sensor, 1= External pressure sensor</p>

APPENDIX B – COMMAND LIST

		<p>2nd Byte 0x <u>1</u> <u>1</u> <u>1</u> <u>1</u> <u>1 1 1 1</u> 5 4 3 2 1</p> <p><i>1:Valve Control</i> Standard 0x0 (Disable C1, X2, X3, XA) Customized 0x1- 0xF</p> <p><i>2:Flow Calibration</i> One Set of Calibration 0 Two Set of Calibration 1</p> <p>3: Relative Measurement 4: Digital Input Pulse/Level Set to 1 if Level detection is desirable 5: Vacuum Testing Message 1—Vacuum</p> <p>1st Byte</p> <p>Bit 0: Measurement Unit Mass Flow Base 1 µg/min as Base Unit Volume Flow Base 0 cc/min as Base Unit</p> <p>Bit 1: Gas Compensation Gas Compensation 1 No Coef Compensation 0</p> <p>Bit 2: 3rd Test Type On</p> <p>Bit 3: 3rd and 4th Test Type On Example: 0x00(1st byte) 27(2nd byte) 00(3rd byte) 02(4th byte)</p>
U3	Integer	<p>Temperature Unit: 0-Degree C 1-Degree F</p>
U4	Integer	<p>Pressure Unit: Pressure Unit: 0- kPa-a 1-kg/cME2 2-psia 3-inHg 4-inH2O 5-psig 6-Torr 7- kPa-g 8- Bar-a</p>
U5	Integer	<p>Flow Unit:</p>

APPENDIX B – COMMAND LIST

		<p>High Nibble 0 - cc 1 – mm3 2 -liter 3-gal 4 -gram 5 -mg 6- µg</p> <p>Lower Nibble 0 -sec 1 -min. 2 -hour 3-SCCM etc.</p> <p>16*HighNibble+LowNibble</p> <p>Besides: 7*16+3-SCCM 8*16+3-SLM 9*16+3-SCFM</p> <p>7*16+4 SCCSe-6</p>								
U6	Integer	0: One string of response to SQ1 command 1: two string of response to SQ1 command								
U7	Integer	Baud Rate: 0, and else: 9600 2:19200 4:38400 12:115200 <u>The Parameter will take effect after the power reset of the sensor</u>								
U8	Integer	Hold Value Time in U8*10 ms								
U9	Integer	Set U9 =0 to disable the some of the special features. 1) Disable Relative Measurement 2) Disable Mass Extraction Test 3) Disable Early Detection for Adaptive Test								
UA	Integer	Start Cycle Counter. Cycle number can be shown on system and maintenance screens								
UB	Integer	Reference flow function flag. 1 Byte Within each byte of the above value the bit positions are numbered as shown: <table border="1" style="display: inline-table; vertical-align: middle;"> <tr> <td style="padding: 2px 5px;">7</td> <td style="padding: 2px 5px;">6</td> <td style="padding: 2px 5px;">5</td> <td style="padding: 2px 5px;">4</td> <td style="padding: 2px 5px;">3</td> <td style="padding: 2px 5px;">2</td> <td style="padding: 2px 5px;">1</td> <td style="padding: 2px 5px;">0</td> </tr> </table>	7	6	5	4	3	2	1	0
7	6	5	4	3	2	1	0			

APPENDIX B – COMMAND LIST

Bit #	Description
0	Reference Flow Activate: 0 = Reference Flow disabled from setup 1 = Reference Flow Enabled from setup
4	0 = TT1 Reference Flow activated if it is enabled 1= TT1 Reference Flow deactivated
5	0 = TT2 Reference Flow activated if it is enabled 1= TT2 Reference Flow deactivated
6	0 = TT3 Reference Flow activated if it is enabled 1= TT3 Reference Flow deactivated
7	0 = TT4 Reference Flow activated if it is enabled 1= TT4 Reference Flow deactivated

B.15 V Group

Command	Type	Note
V1	float	Min. Flow Alarm for leak test mode in cc/min, $\mu\text{g}/\text{min}$ or selected unit based on X6.
V2	float	Max. Flow Alarm for leak test mode in cc/min. or selected unit based on X6. For mass extraction method, Max. Leak Alarm for leak test mode in cc, μg , or selected unit based on X6
V3	float	flow compensation to DP in kPa/(cc/min) or kPa/($\mu\text{g}/\text{min}$)
V5	float	Min. Flow Alarm for Relative Measurement BaseLine Flow in cc/min, $\mu\text{g}/\text{min}$ or selected unit based on X6.
V6	float	Max. Flow Alarm for Relative Measurement BaseLine Flow in cc/min. or selected unit based on X6.
V7	float	Large Leak Flow Alarm Flow in cc/min. or selected unit based on X6.

B.16 X Group

Command	Type	Note
X1	Integer	Pressure Switch On Check Step No Lowest Byte=Step No <i>2nd Lowest<>0, Advance to the next step once the PS is on (ver 2.1.1)</i>
X2	Integer	Pressure Switch Off Check Step No Lowest Byte=Step No <i>2nd Lowest<>0, Advance to the next step once the PS is off (Ver 2.1.1)</i>
X3	Integer	Leak Check Step
X4	Integer	Buffer Size: Valid from 4 to 100
X5	Integer	Enable Flag: Deplete the pressure after the test failure

APPENDIX B – COMMAND LIST

X6	Integer	Default unit is used if X6 <>0 Flow in cc/min or µg/min. pressure in kPa and temperature in Degree C
X9	Integer	Flow baseline Step No
XA	Integer	Stop Test Step No
XB	Integer	LargeLeak Test Step No (<i>ver 2.1.2</i>) Lowest Byte=Step No <i>2nd Lowest<>0, The steps before and on LargeLeak will be set based on K5 and check against K6 and K7</i>
XC	Integer	<i>Basic Check (ver2.2.0)</i> <i>Each bit of the integer representing the step in which the basic check shall be enforced.</i> <i>The Basic Check verifies the sensor is not saturated and pressure is not out of settings (P_{Hi} and P_{Lo}). "XC"</i> <i>Note:</i> <i>1. If XC was set such as 0xFF, the gross leak check will be disabled.</i> <i>2. Any basic step check after leak check step will be ignored!</i> <i>Example of setting:</i> <i>XC=0x06 In step 2 and step 3 the basic check will be enforced.</i>
XD	Integer	<i>External Pressure On Step No</i> Lowest Byte=Step No <i>2nd Lowest<>0, Advance to the next step once the external pressure is in range</i>
XE	Integer	<i>External Pressure Off Step No</i> Lowest Byte=Step No <i>2nd Lowest<>0, Advance to the next step once the external pressure is out of range</i>

Note:

The following condition has to be met in order for the IGLS to function properly:

- X1<X3<XA<X2
- XB<X9<X3
- 1<X3
- 1<XB

B.17 Y-Group

Command	Type	Note
Y1	float	Reference Flow the first point time parameters.
Y2	float	Reference Flow the second point time parameters.
Y3	float	Reference Flow the third point time parameters.
Y4	float	Reference Flow the fourth point time parameters.
Y5	float	Reference Flow the fifth point time parameters.

B.18 Z-Group

Command	Type	Note
Z1	float	Reference Flow the first point flow parameters.
Z2	float	Reference Flow the second point flow parameters.
Z3	float	Reference Flow the third point flow parameters.
Z4	float	Reference Flow the fourth point flow parameters.
Z5	float	Reference Flow the fifth point flow parameters.

NOTE:

Commands implemented in 2.0.0 or later ONLY are in bold.

APPENDIX C - Quick Reference Flow setting process

The quick reference flow setting function must be activated via Leak-Tek before it can be set on sensor. After it is activated, user can follow the below steps to set the reference flow:

1. Power off the IGLS;
2. Connect the IO extension box if no start stop IO is accessible;
3. Hold the start and stop IO at the same time and power on the sensor, keep holding start and stop for at least one second;
4. For E2 or IPE2, the message "Reference Flow teach Mode" will be shown on the top of the LCD screen, for EPDQ, the Pass and Fail indicators will both on.
5. Run a test with a mast part and closed orifice.
6. If successful, the message "Reference Flow set success" will display on the top of the LCD screen and it will disappear after the start a new test.

In order to be successfully set, the reference flow must be smaller than the 10% of the full scale of the sensor, that means the AD count cannot over 6,553, else the set is failed and a message "RF Set Fail, ADC too High" will be shown on the top of LCD instead of the successful message. If it failed, the user needs to repeat all the steps above to set the reference flow again.

APPENDIX D - Specification Sheet

MODEL NUMBER: _____

S.N.: _____

SOFTWARE VERSION: _____

FLOW RATE: _____ $\mu\text{g}/\text{min}$. _____ gm/min . (Fill One)
10% to 100% of mass flow range

FLOW MEASUREMENT UNCERTAINTY: +/- _____ % OF READING

PRESSURE RANGE: _____ PSIA

MAXIMUM PRESSURE: _____ PSIA

MAXIMUM PRESSURE DIFFERENTIAL CONTINUOUS: _____ PSID

STATIC: _____ PSID

PRESSURE MEASUREMENT UNCERTAINTY: +/- 0.2% OF FULL SCALE AT OPERATING TEMPERATURE.

TEMPERATURE OPERATING RANGE: 10 - 45°C

TEMPERATURE MEASUREMENT UNCERTAINTY: +/- 0.5°C WHEN GAS FLOW IS AT STEADY STATE OF CONDITION

NOTE:

All uncertainty statements are at a 95% confidence level, referenced to primary standards traceable to NIST. Uncertainty statements comply with ANSI/NCSL Z520-Z-1997 "US guide to the expression of uncertainty in measurement".

APPENDIX E - IGLS Application Setup Example

Large Volume Setup with Large Flow Example:

Description	Time (sec)	Parameter
Clamping Delay	1	T4=40
Evac Delay	200	T1=8000
Stability Delay	200	T2=8000
Test Delay	10	T3=400

Figure D.1 - Test Time Setting

Description	Setting	Parameter
Proportional	2000	P1=2000
Integral	400	P2=400
Differential	1	P3=1
Damping Coefficient	0.02	V4=0.02

Figure D.2 - PID Coefficient

Description	Enabled	Disable
Clamping Valve	X1=1	X1=0
Evac Valve	X2=1	X2=0
Pressure Valve	X3=1	X3=0
Deplete After Failure	X5=1	X5=0

Figure D.3 - Valve Setting

Description	Setting (kPa)	Parameters
Pressure Setting	200	K1=200
Pressure Upper Limit	210	K2=210
Pressure Lower Limit	190	K3=190
Pressure Control Offset	-1	K4=-1

Figure D.4 - Pressure Setting

Description	Setting (cc/min)	Parameters
Flow Min.	-1 (Disabled)	V1=-1
Flow Max.	1000	V2=1000

Figure D.5 - Flow Criteria

APPENDIX D IGLS APPLICATION SETUP EXAMPLE

Description	Setting (kPa)	Parameters
Ext Pressure Lower Limit	210	K9=210
Ext Pressure Higher Limit	190	KA=190

Figure D.6 – External Pressure Setting

Appendix E – ME2 Dimensions

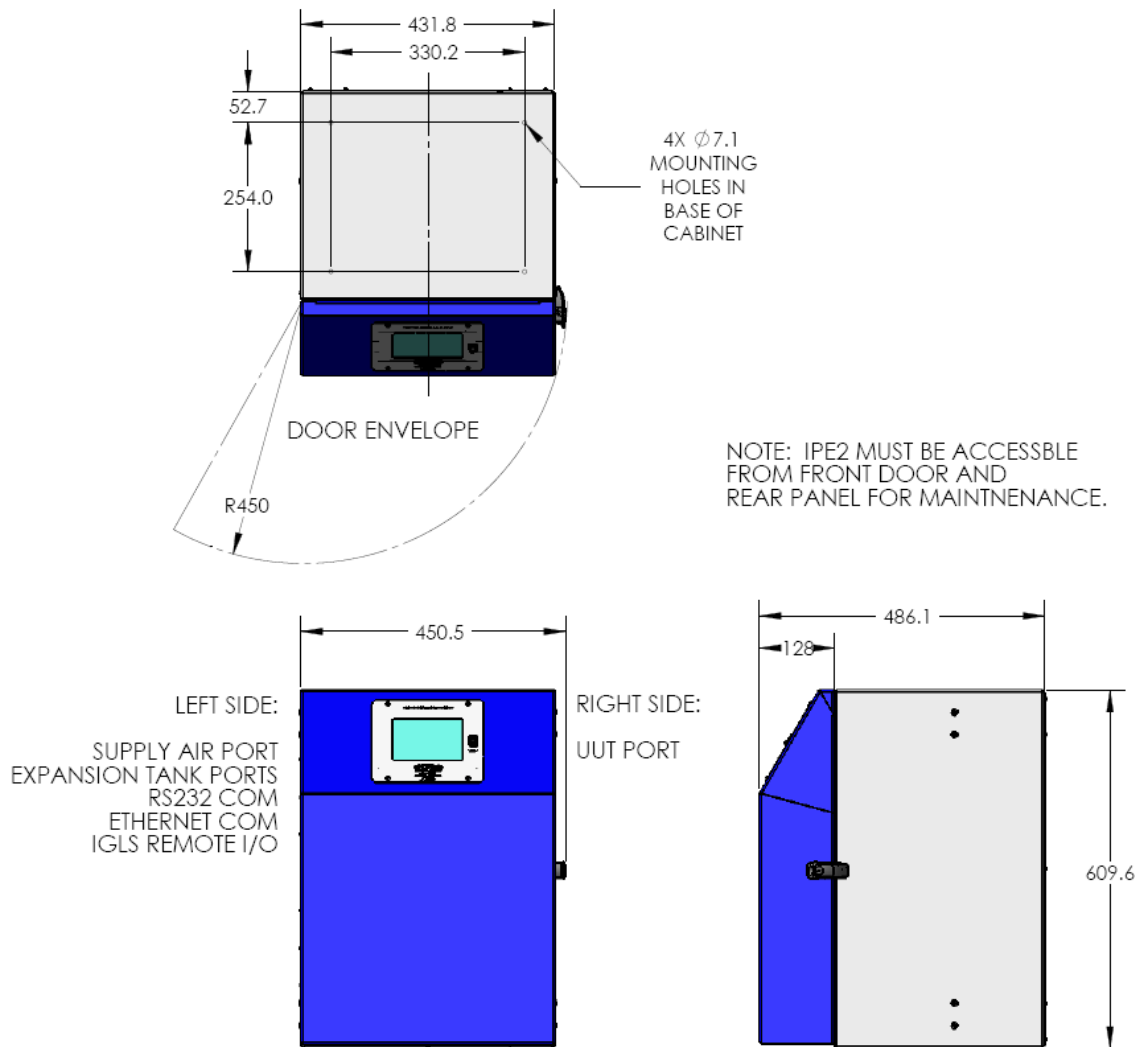

Figure E.1 – Dimensions of ME2.

Note: Does not include fittings.